

HFT Software Status

S. Margetis, KSU

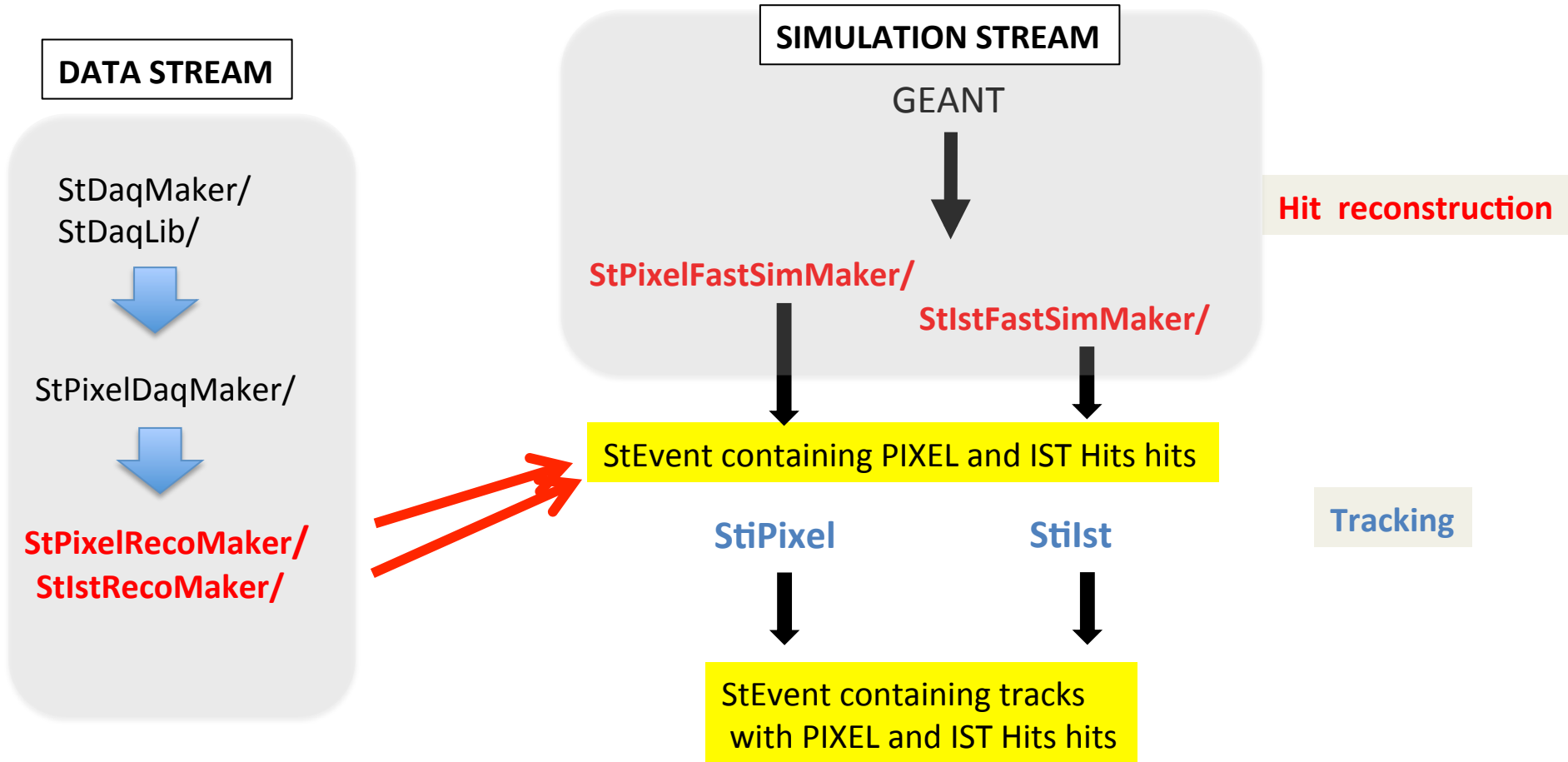

Outline

- Brief overview of subsystem
- Technical Progress since last review
- Construction Plans
- Outstanding technical issues and plans
- Schedule & Cost
 - Cost to date and projection (from Sarah)
- Resources
 - People, institutions and
- Risk assessment; value engineering
- Summary

Overview of subsystem

- WBS 1.6 (Software) is the sum of Online and Offline software tasks
- The Online software is a sub-detector deliverable and contains Slow controls, online monitoring etc
- The Offline software is responsible for the event reconstruction, starting from raw data all the way to particle quantities. It includes tasks like alignment, hit/track/vertex finding etc
- WBS 1.6 is divided into two parts. Part one (on-scope) contains all the essential tasks for the successful operation of the detector (calibrations etc). Part two contains the remaining tasks.
- Subsystem meets weekly to plan work and get updates. Participates in weekly TC meetings as well.
- Subsystem is an integral part of STAR's S&C environment, interacting very closely with it on a regular basis.

General Flowchart of Software Tasks Offline/Online

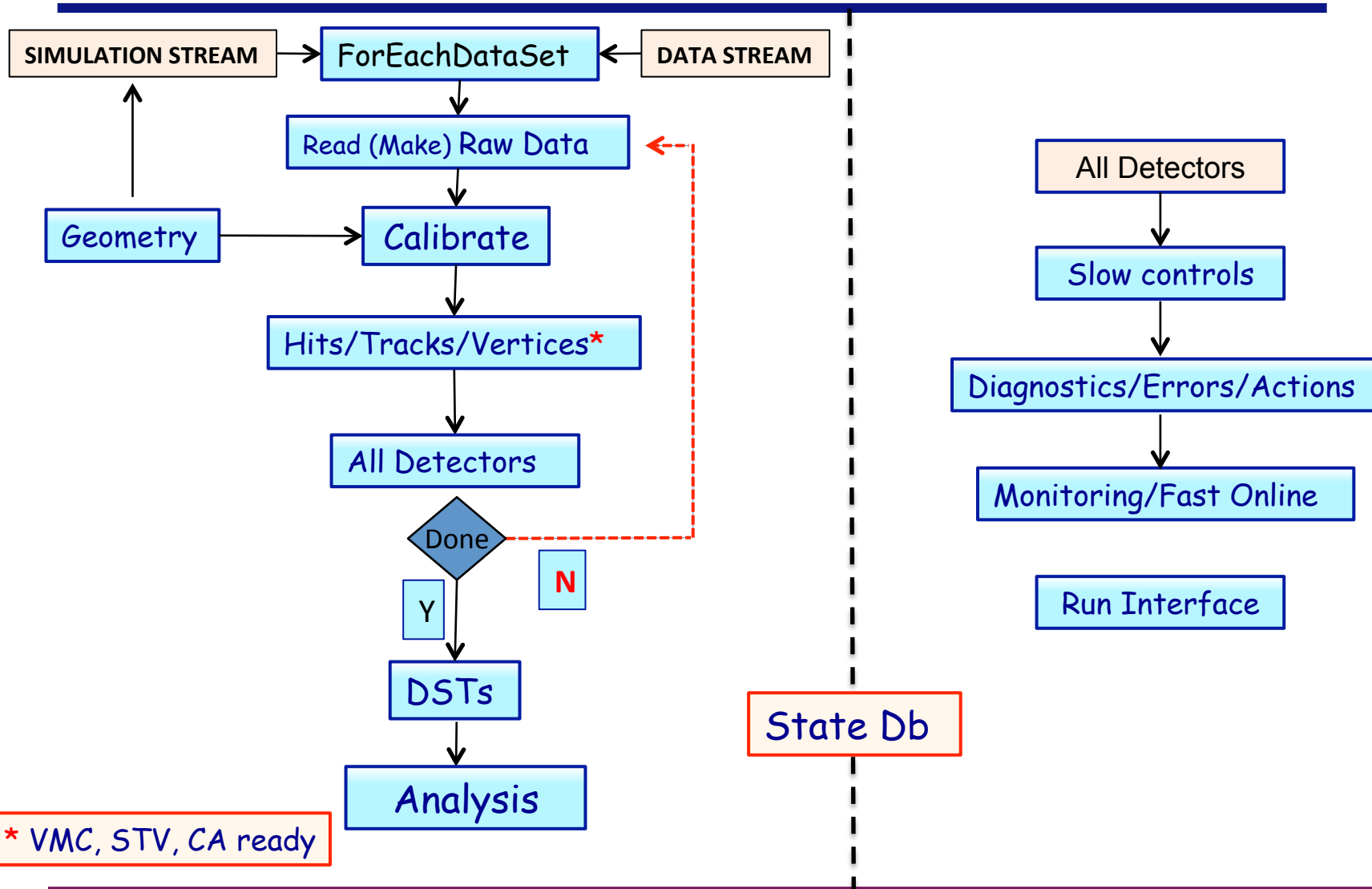

-
- Brief overview of subsystem
 - Technical **Progress** since last review
 - Construction Plans
 - Outstanding technical issues and plans
 - Schedule & Cost
 - Cost to date and projection (from Sarah)
 - Resources
 - People, institutions and
 - Risk assessment; value engineering
 - Summary

Areas of activities since CD2/3 (a year ago)

- HFT Geometry model
 - **HFT Survey & Alignment** related work
 - Slow/Fast PXL response simulation
 - Prototype (BUR) simulations/tracking
 - Offline structures (Hits etc)
 - Simulation environment (UPC e⁻ background, Pileup)
 - Conventions (naming scheme defined), Db
-
- **Hit/Event vertex finders/Kalman fitter** for decays
 - Evaluation/Analysis framework (see Jonathan's talk)
 - Tests of new STV tracker, VMC environment
-
- **'Online' data format/slow controls/online QA/Db considerations**

HFT Geometry model update

- Creating the Y2013/14 geometry in AgML based on Solid-Works Models
- We had an internal review in March, working on recommendations etc
- Work on SSD/IST in progress
- Work on details of support structures etc in progress
- Manpower probably O.K. but we seek more help

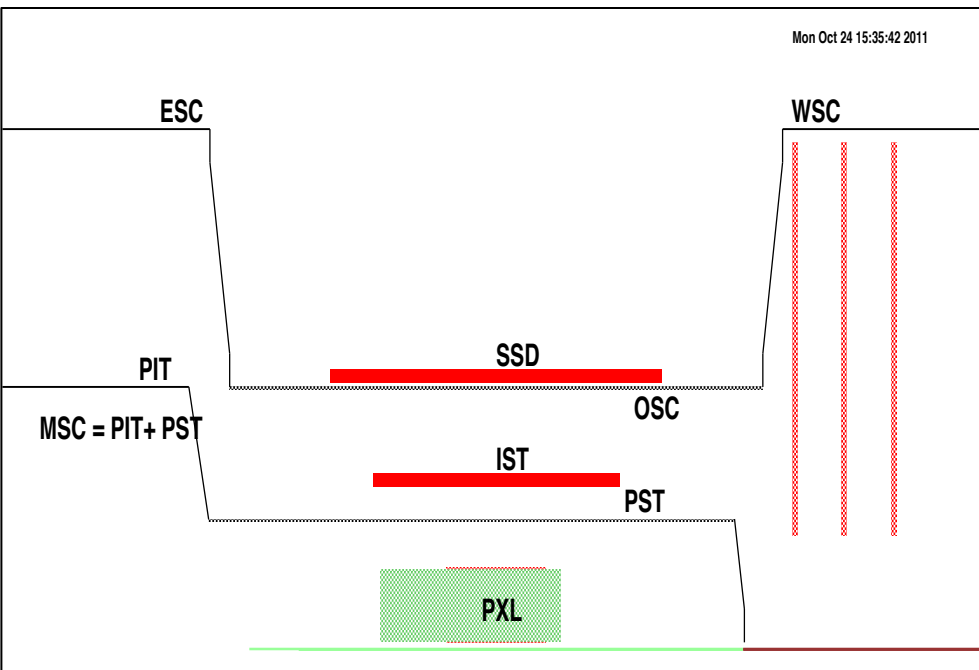

Inner Detector Support

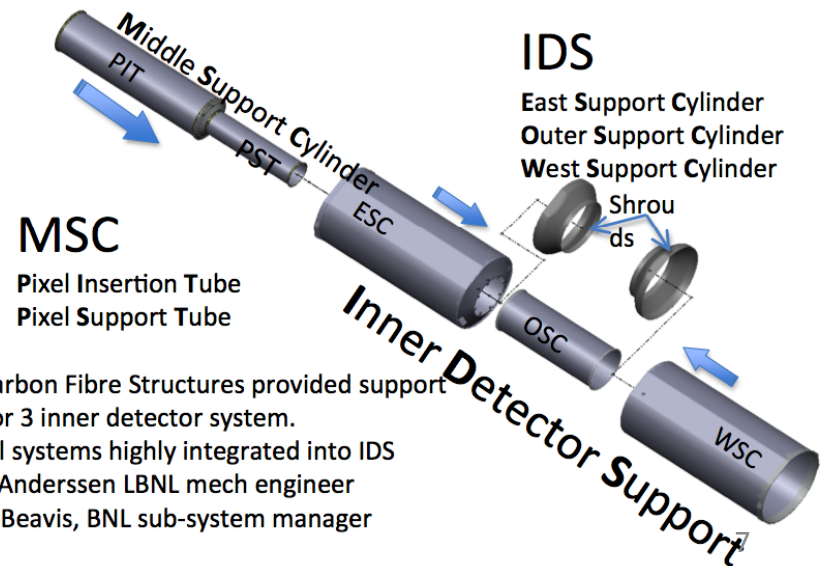

PXL sector modeling in GEANT

- detailed work on structure and thickness (shape and material)
- optimization in progress

GEANT NAME	piece	shape	Composition / mixture	Radiation length [cm]	Density[g/cm ³]
PLAC	Silicon active	box	Si	9.36	2.33
SIFR	Silicon passive	box	Si	9.36	2.33
SIFL	Silicon passive	box	Si	9.36	2.33
GLUA	adhesive	box	O(0.164) C(0.763) H(0.073)	34.7	1.2(*)
GLUB	adhesive	box	O(0.164) C(0.763) H(0.073)	34.7	1.2(*)
GLUC	adhesive	box	O(0.164) C(0.763) H(0.073)	34.7	1.2(*)
ALCA	Aluminum cable	box	Al	23.7(*)	2.7(*)
CBFK	Carbon Fiber backing	box	C	68(*)	1.3(*)

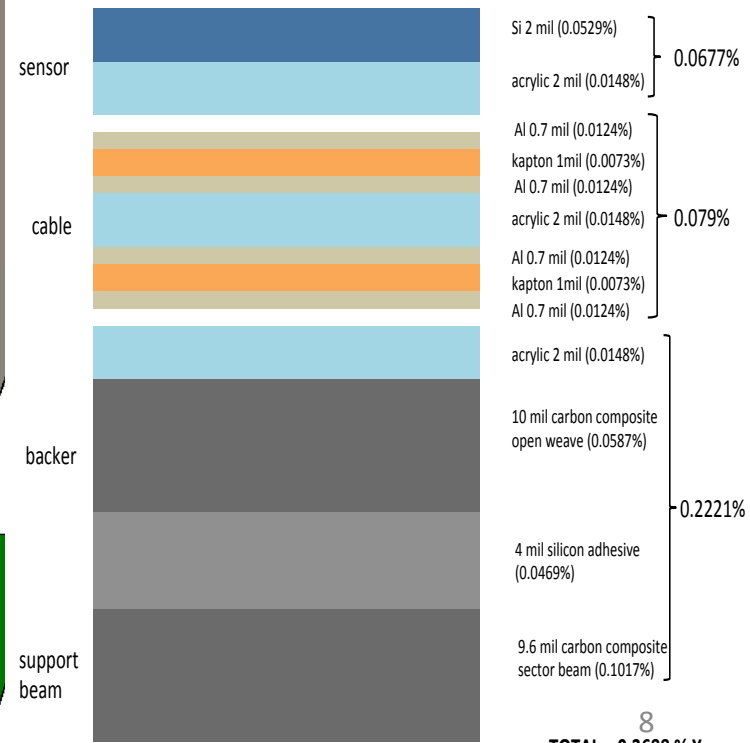
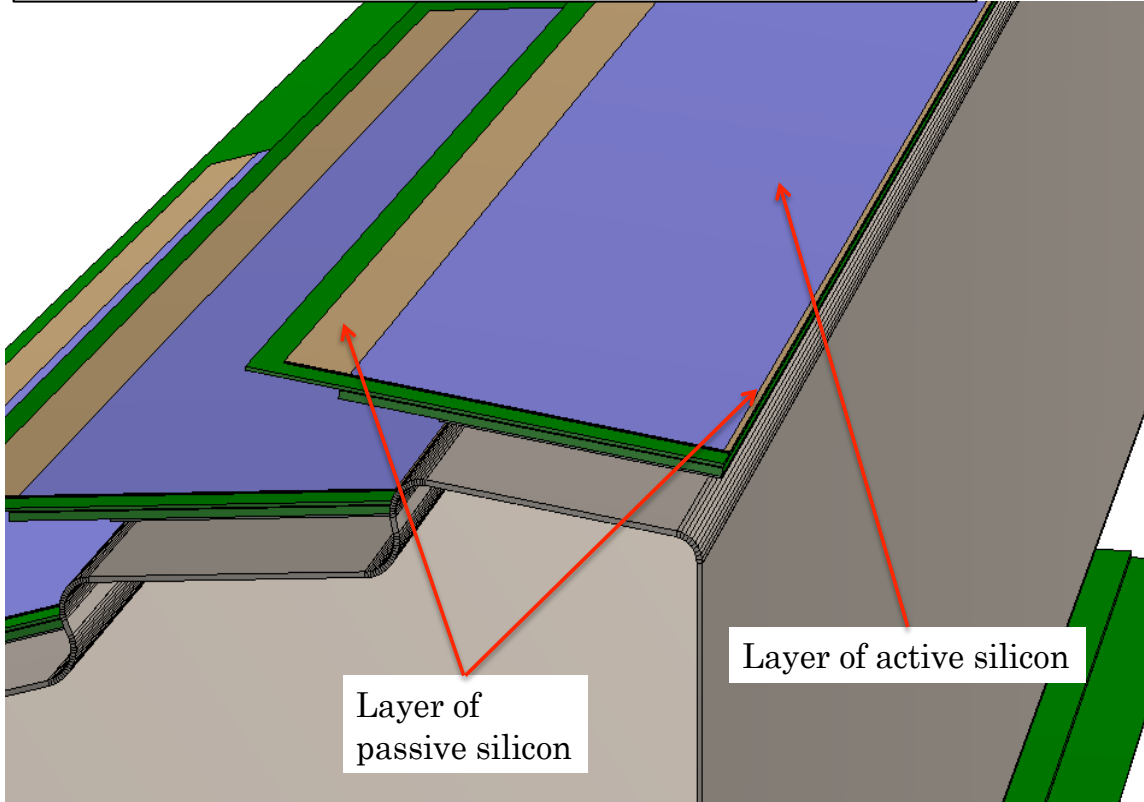
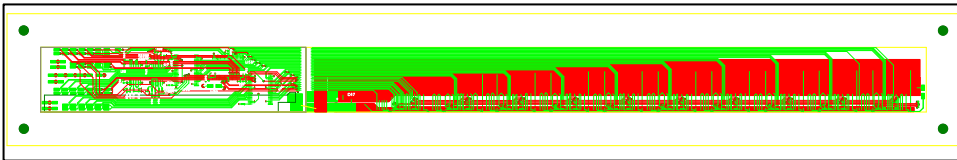

8
TOTAL = 0.3688 % X₀

IDS modeling

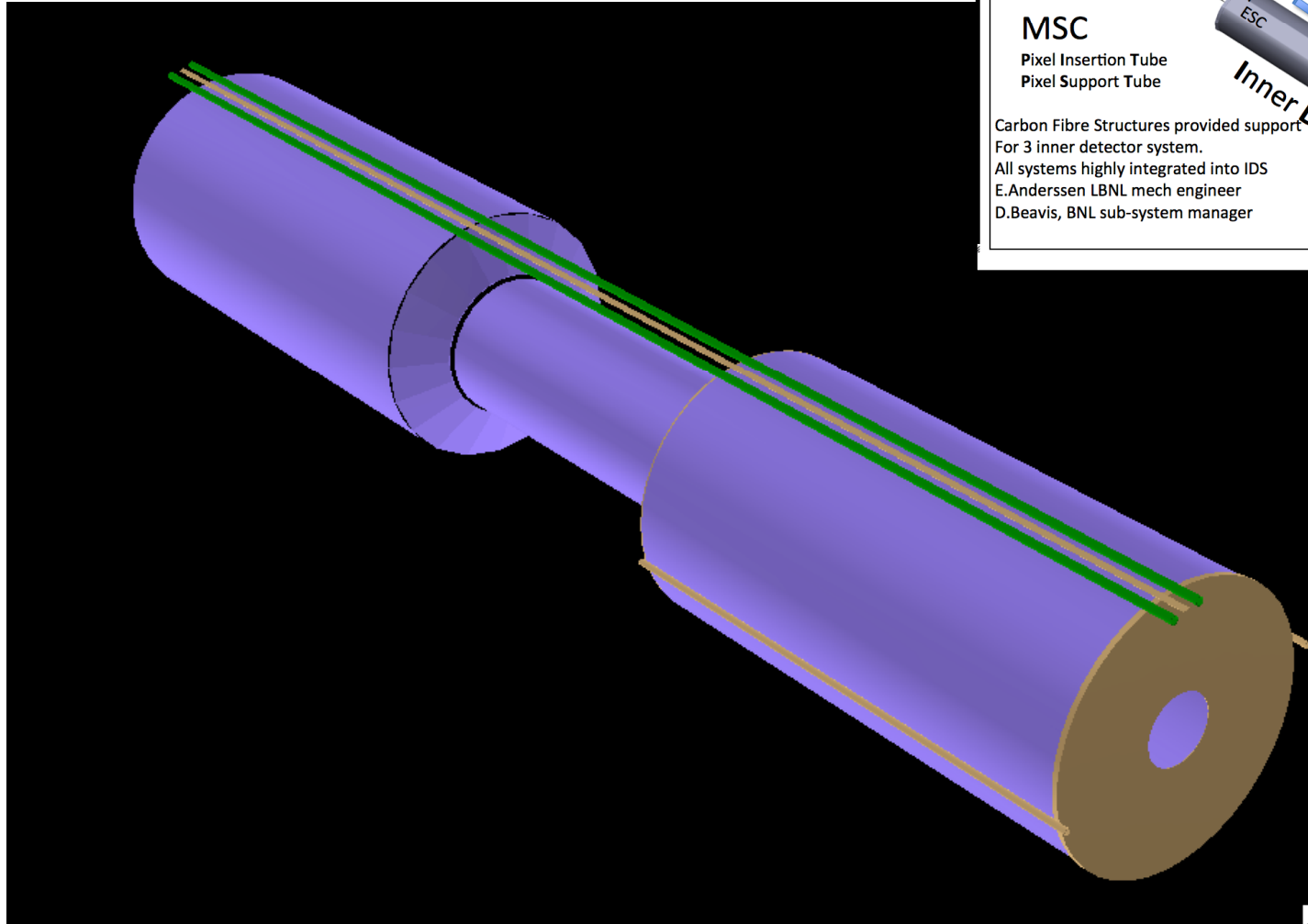

Inner Detector Support

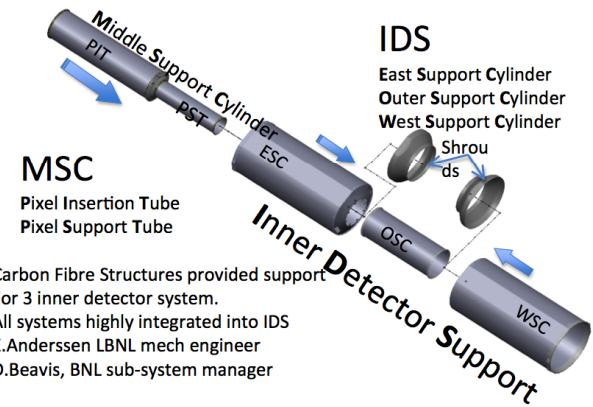

MSC modeling

OVERVIEW OF THE MSC

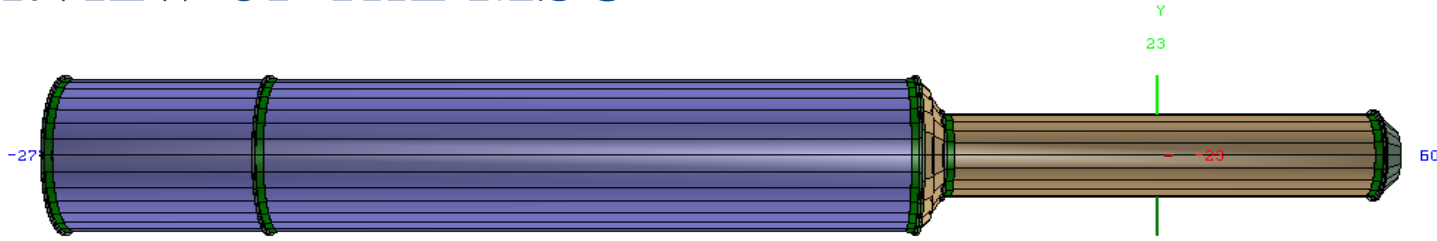

rails

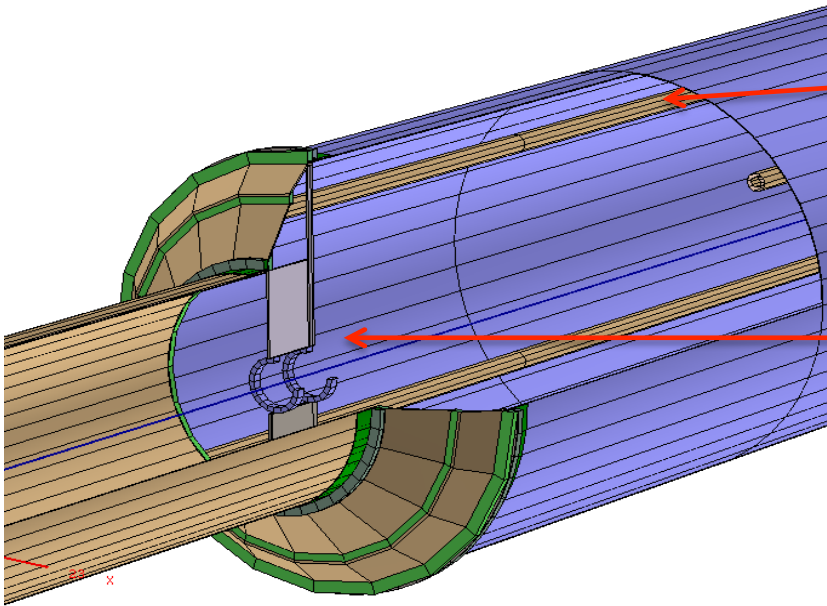

Rings surrounding the beam pipe

•: temporary until implementation of real material (slide 39)

GEANT NAME	piece	Composition / mixture	Radiation length	density
ALL(*)	Carbon Fiber	C	23.9	1.3(*)

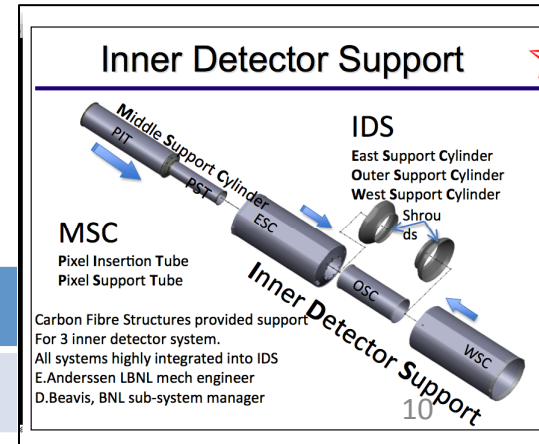

HFT Survey work

- PXL+SSD work has already begun, IST is setting up
 - Single chip and 3-chip ladder done. Full PXL sector (photo) in progress
 - SSD ladder preliminary survey done, parameter space defined
 - IST preliminary work on prototype ladder about to begin at BNL
- We had an internal review on procedures/general scheme in May
- A lot of detailed work in front of us, but expertise is building up
- Manpower issues addressed (most) but there are tasks available

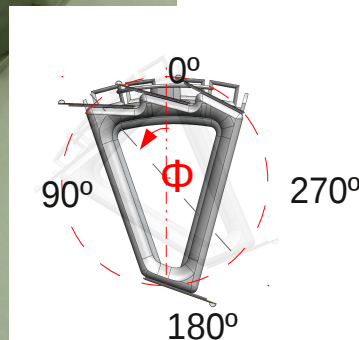
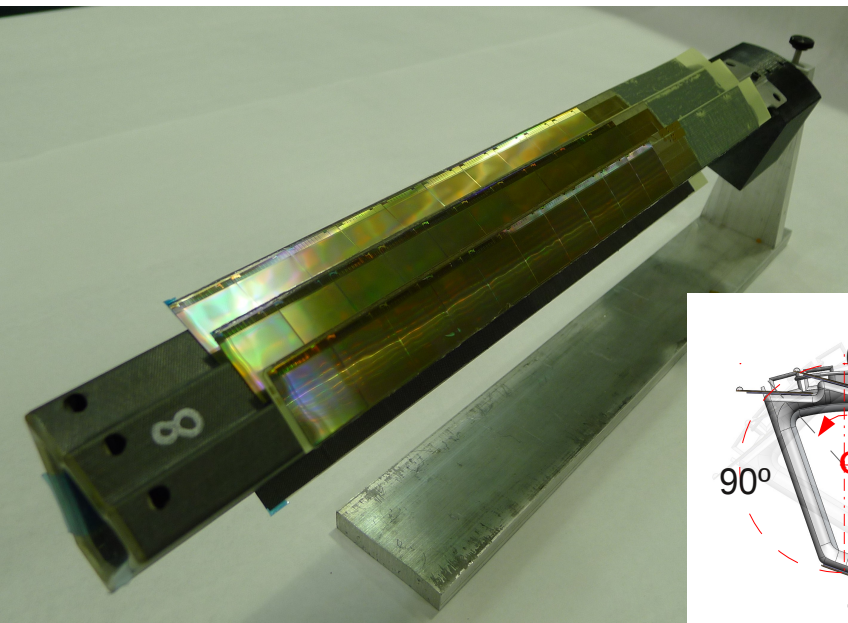

Difference from plane

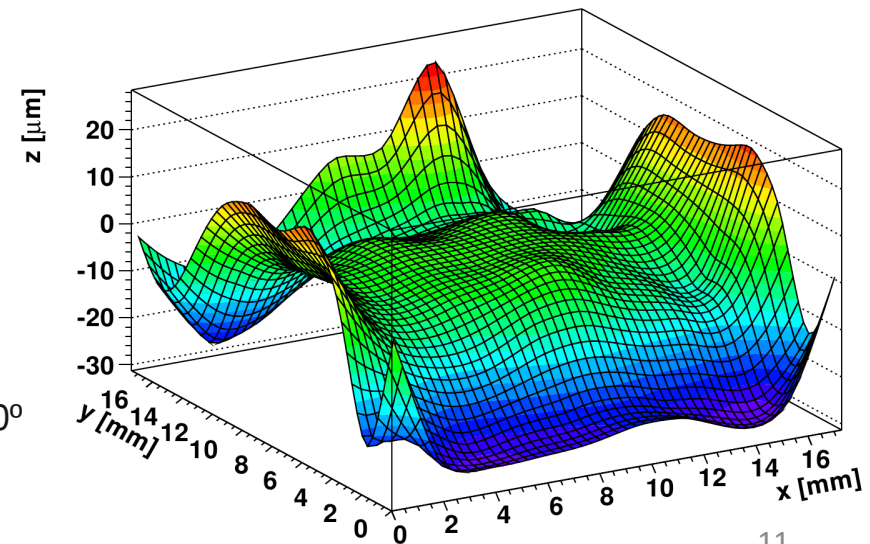

Sensor's features for individual pixel coordinates identified
- Need be programmable for automating process



$x=4594.225 \mu\text{m}$
 $y=10000.00 \mu\text{m}$
 $z=0 \mu\text{m}$

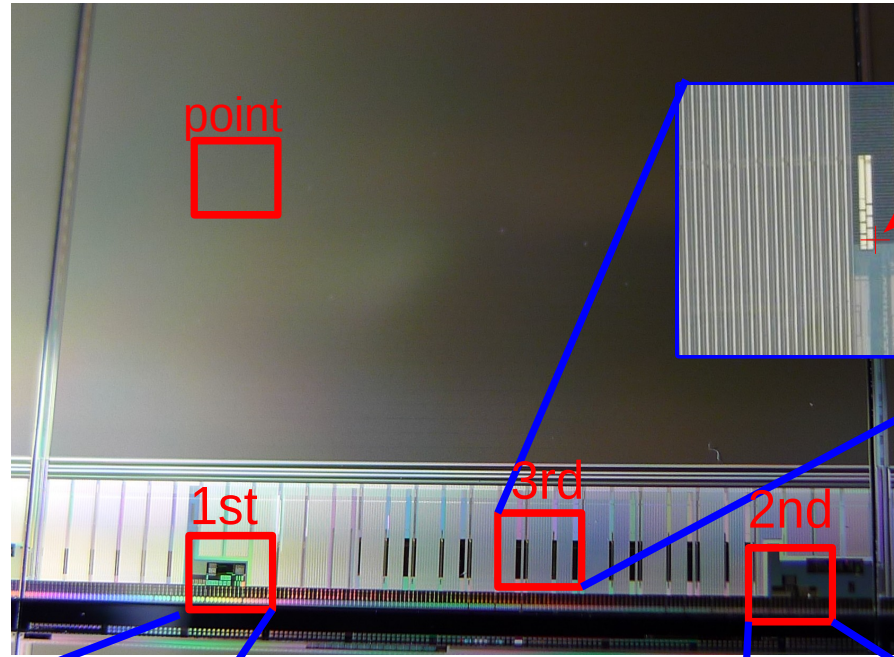

$x=? \mu\text{m}$
 $y=? \mu\text{m}$
 $z=0 \mu\text{m}$

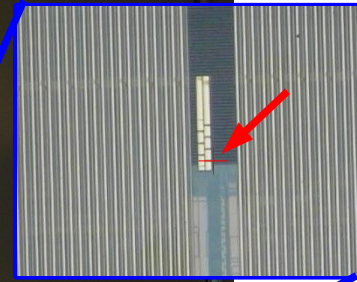

$x=4594.225 \mu\text{m}$
 $y=920.775 \mu\text{m}$
 $z=0 \mu\text{m}$



$x=18165.075 \mu\text{m}$
 $y=871.6 \mu\text{m}$
 $z=0 \mu\text{m}$

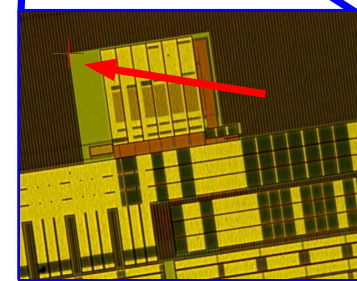

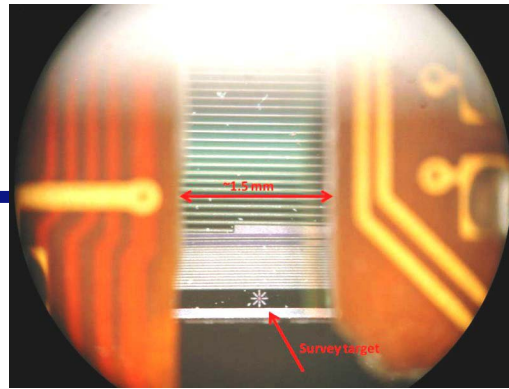
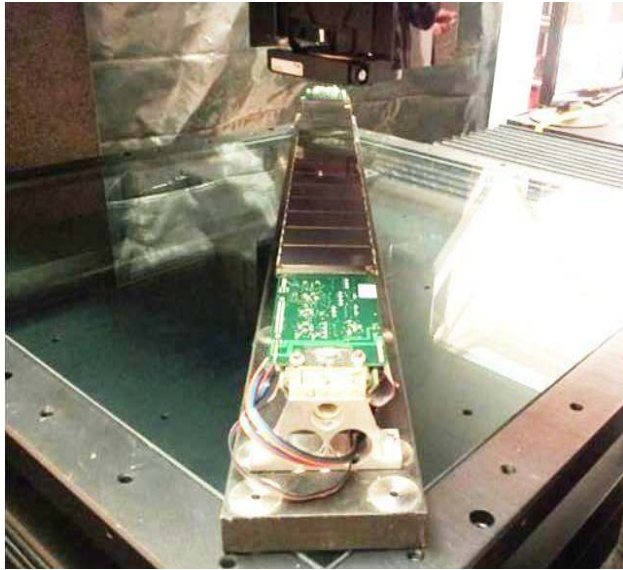

Target on end of wafer (backside)

SSD ladder survey

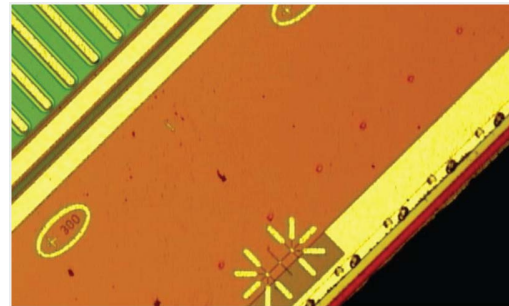

Targets on edges of wafer (front)

Reference point

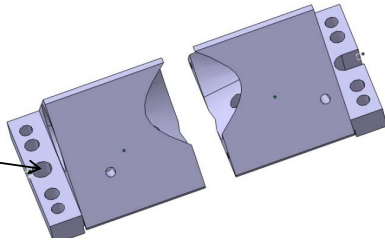

Jim Thomas - LBL

9

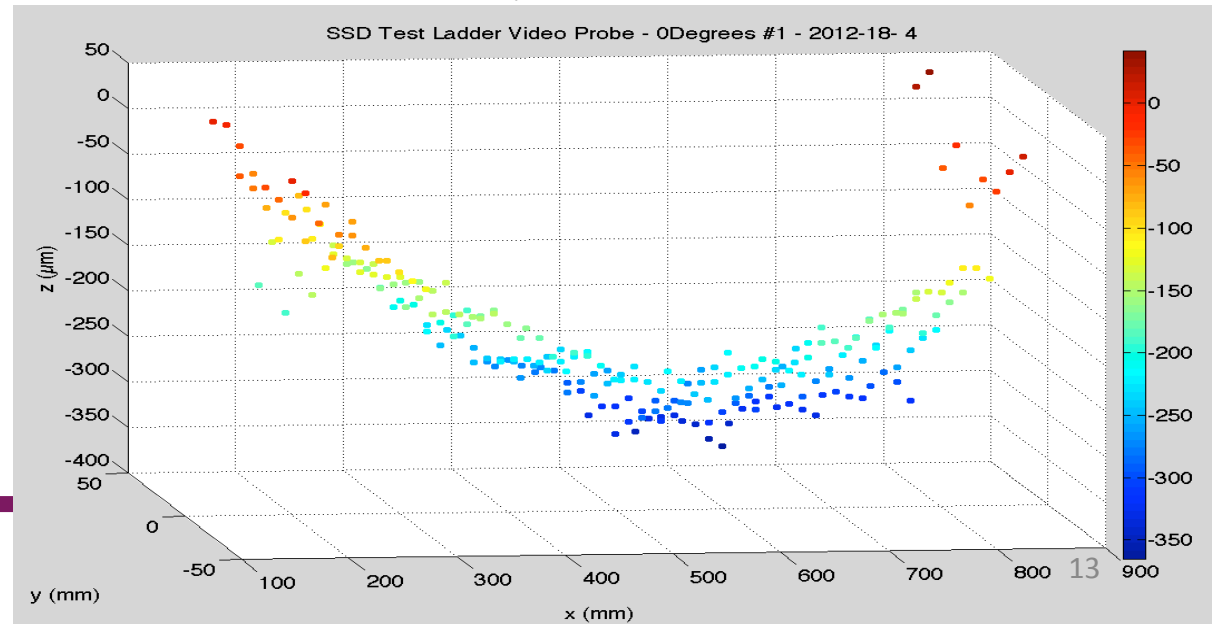

Slow/Fast PXL response simulation

- Most work done by IPHC (Strasbourg) Collaborators
- They have developed a Root program, DIGMAPS, for response studies
- Analyzed CERN test-beam data with our sensors to fix parameters
- We are about to get their tune to use for our studies and compare with default “geometrical mean” approach. Then, build fast simulator with appropriate errors
- SSD simulators exist, IST is relatively simple, but still not there yet
- These are low priority tasks but need to start

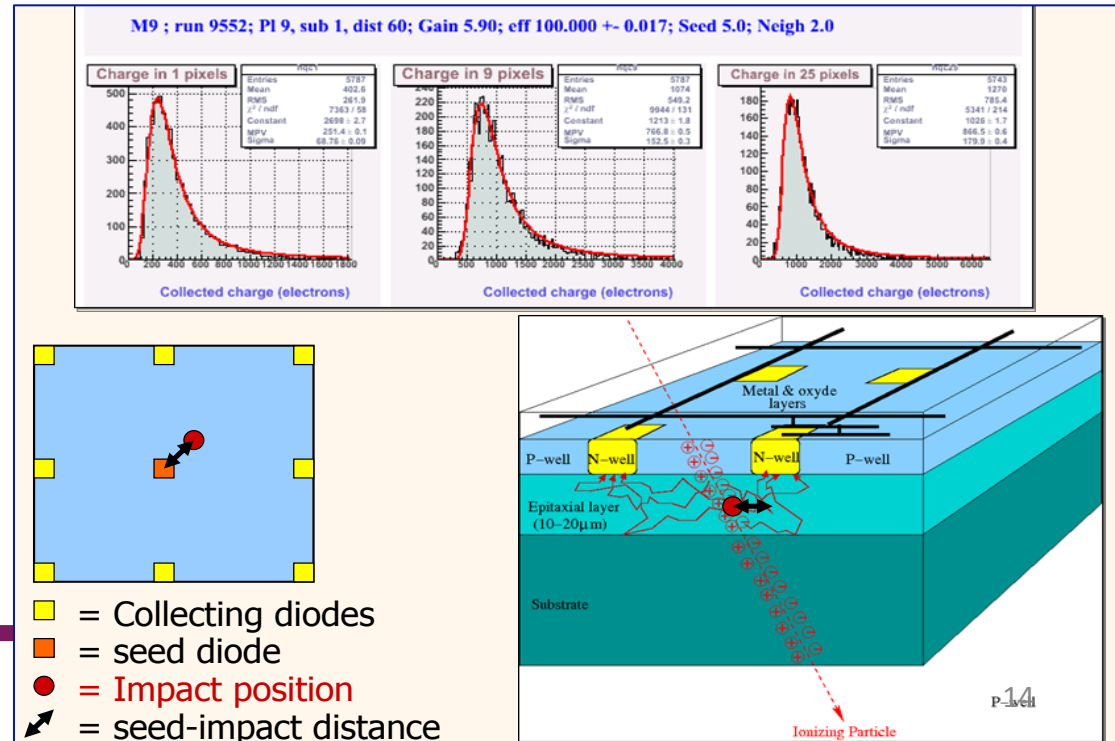
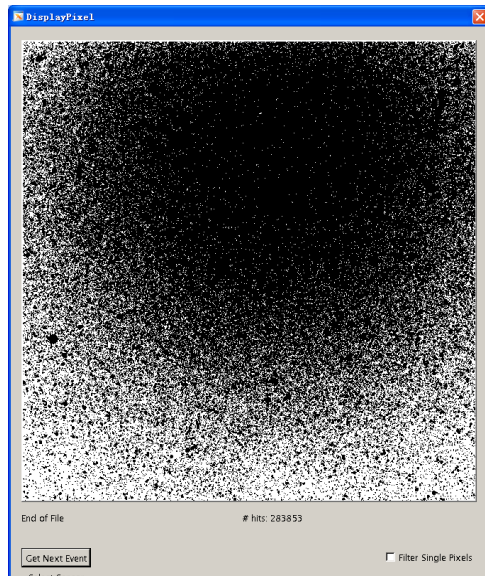

- Tracking (Physics?) with TPC+PXL prototype ?

- BUR simulations done, presented and used as input
- Simulations show (see next slide too) that there might some physics opportunities
- This connects to the bigger issue of Tracking and whether inside-out tracking is possible. Is CA useful? Work in this direction is scheduled
- This is vital work for the project. ANY help and idea is invaluable.

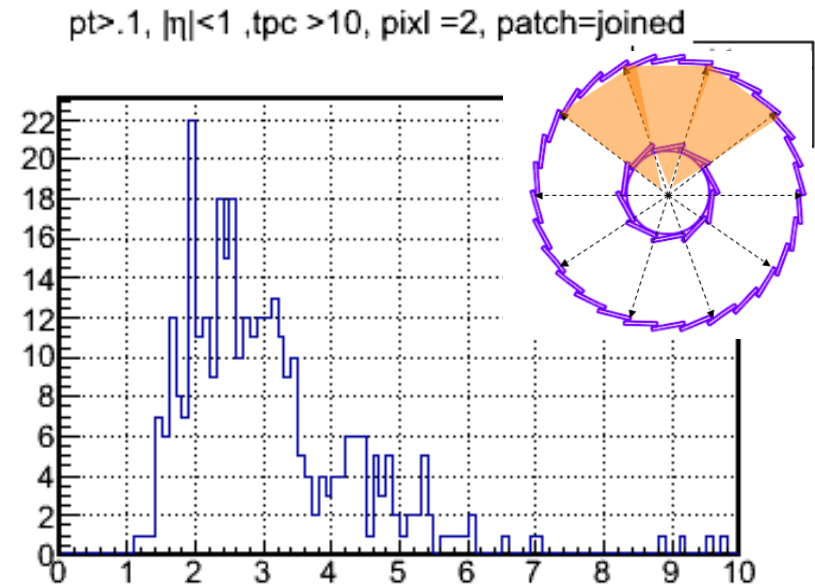
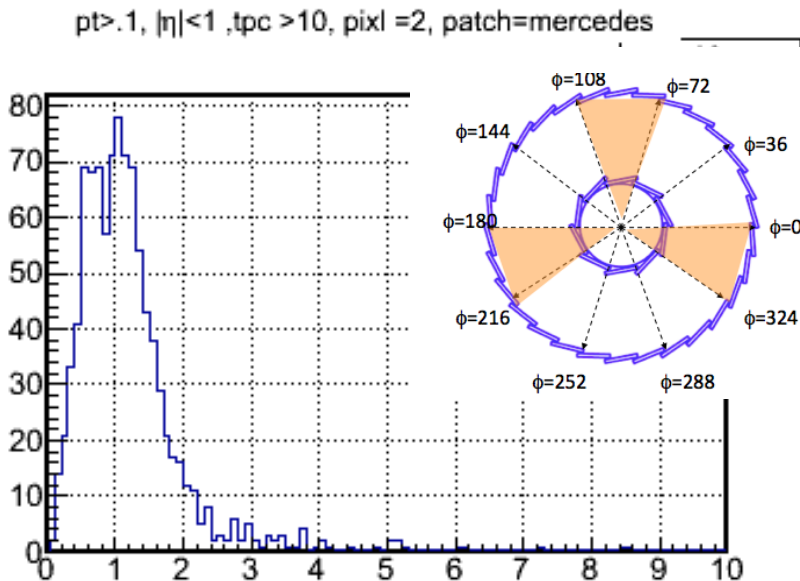

BUR results based on full simulations

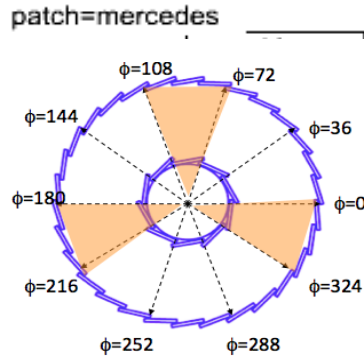

500 M AuAu mbias events

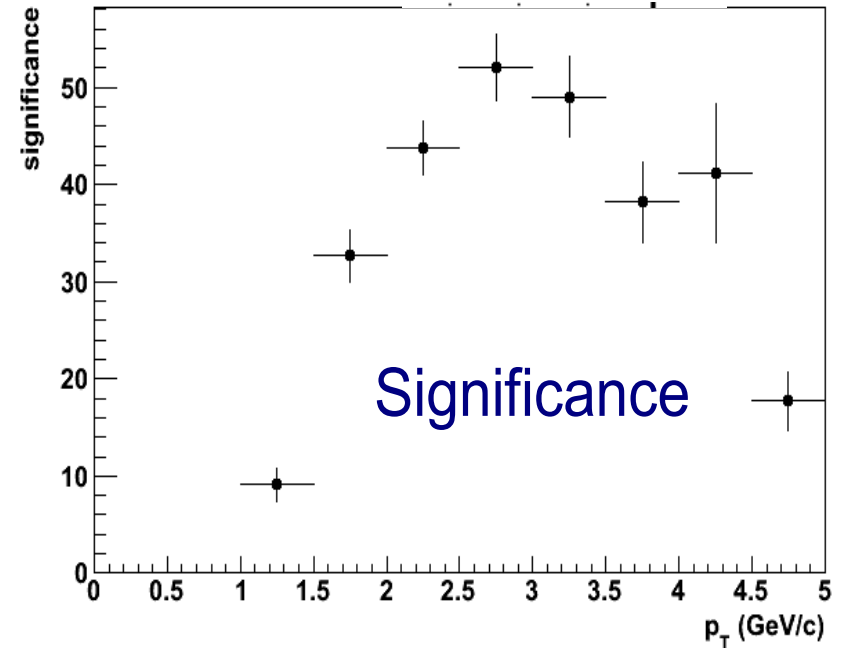
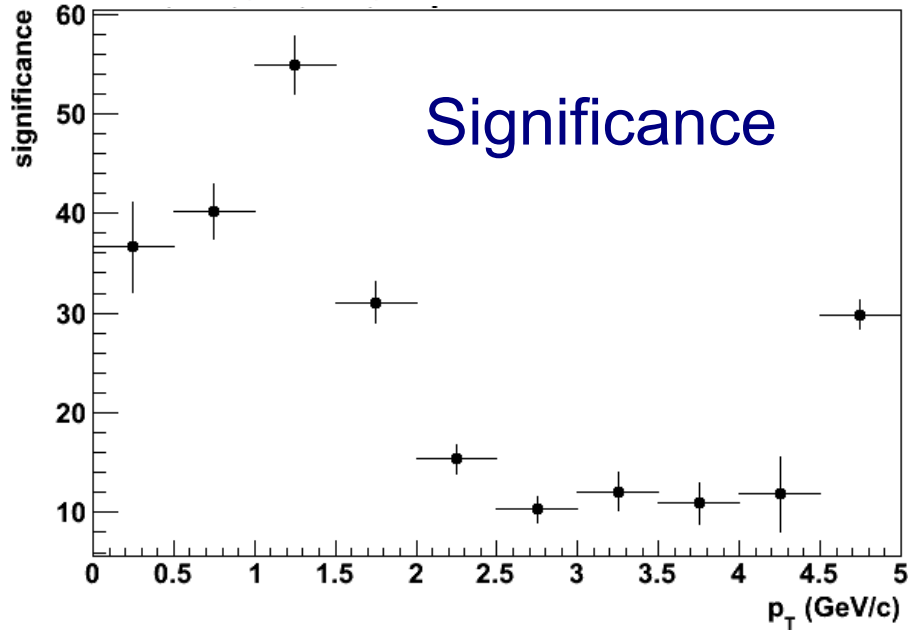
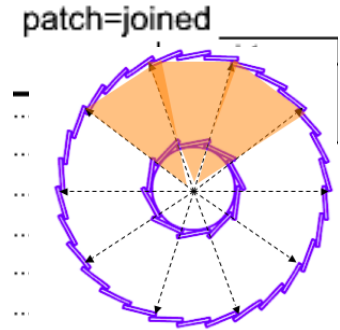

Offline chain - Update

- Establishing a working offline chain
- Modify structures/makers to our needs
- Closely tied to S&C territory !
- Need to stay informed and implement new strategies (e.g. no minimc etc)
- We 've gone through initial loops but not done yet(see 2 slides)
- Expert help invaluable

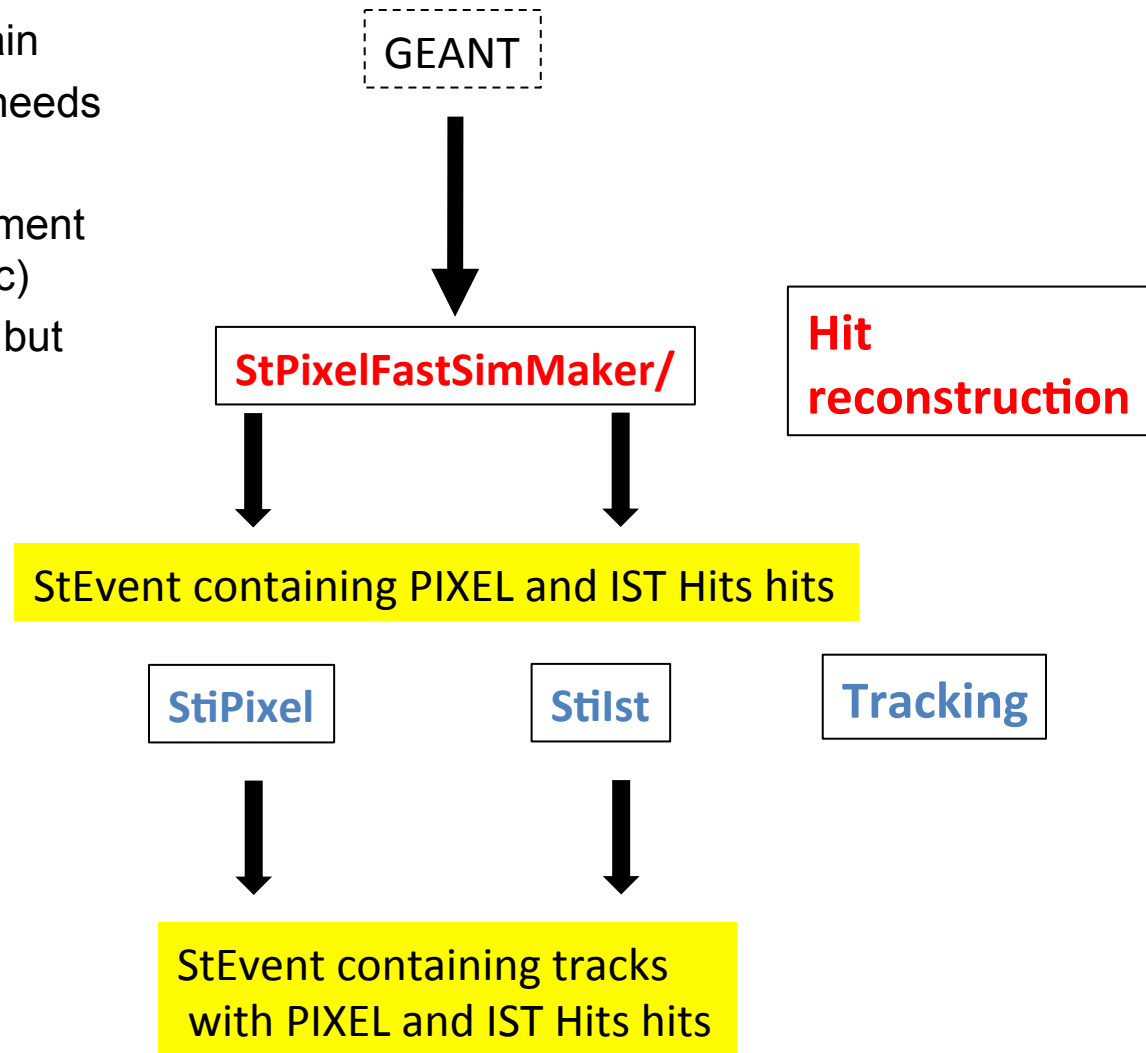

Actual structures

StEvent



StRndHit

StRndHitCollection

Proposed structures

StEvent



StHftHit

StHftHitCollection



- A unique **PIXEL/IST** hit structure and hit collection
- No sub collection (LayerHitCollection, SectorHitCollection) because it is redundant :
 - Make the hits collection *isSortable()* to retrieve the hits the way we want.

Numbering convention/Configuration of detector elements

- We have defined and documented the scheme for all HFT elements
- Complies with STAR conventions
- IST example is shown below

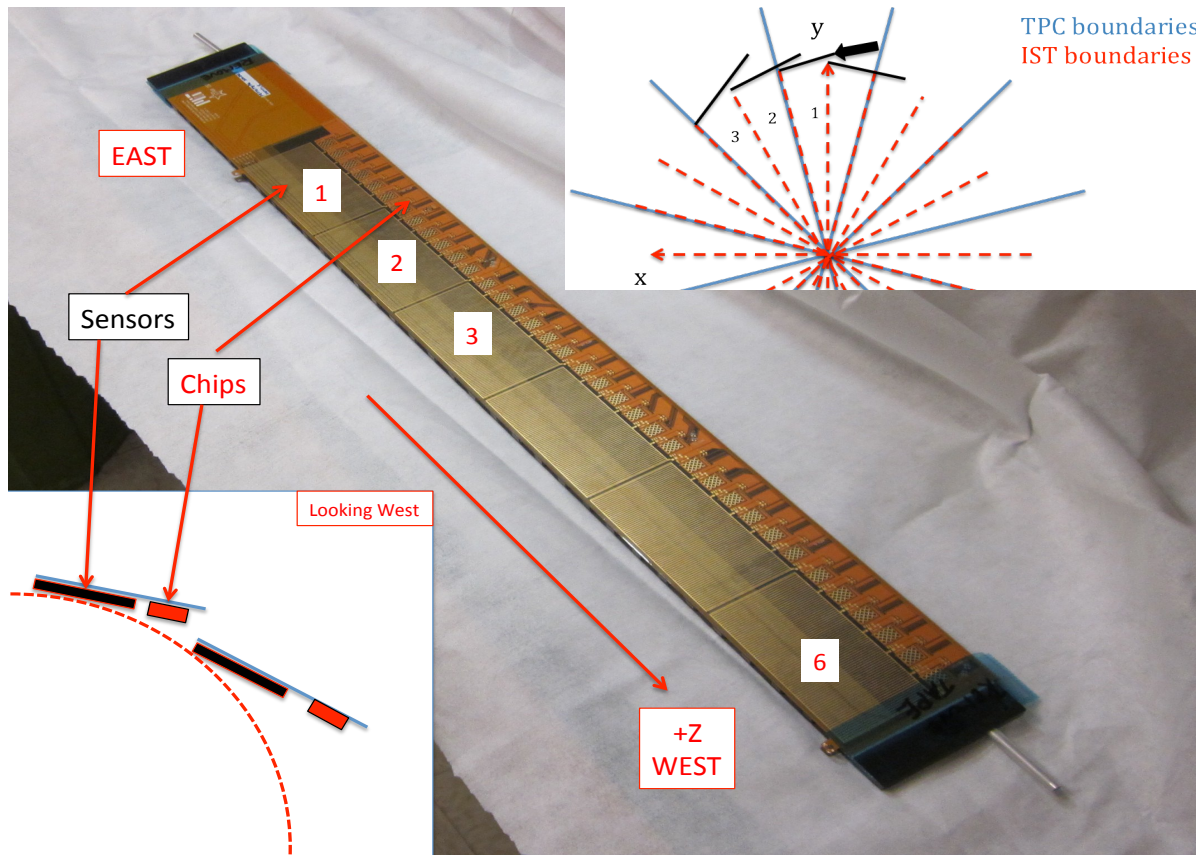

- Simulation environment (UPC e- background, Pileup mechanism)
 - We did improve our understanding and way of generating this
 - We still need to put all this to work with STAR's official pileup scheme
- Event vertex finders
 - Important evaluation work goes on now
- Web Docs
 - Jonathan and I are organizing better our Off-Drupal personal doc areas
 - Jerome provided an AFS area for Off-Drupal (really public) access
 - Drupal pages need rework from scratch

-
- Brief overview of subsystem
 - Technical Progress since last review
 - Construction Plans
 - **Outstanding technical issues and plans**
 - Schedule & Cost
 - Cost to date and projection (from Sarah)
 - Resources
 - People, institutions and
 - Risk assessment; value engineering
 - Summary

Still to do



–Besides things I have already mentioned above

- Raw data unpackers/Cluster-Hit finders
- Tests of new STV tracker, VMC environment
- ‘Online’ data format/slow controls/online QA/Db considerations
- *Make sure we are ready when data starts flowing*

-
- Brief overview of subsystem
 - Technical Progress since last review
 - Construction Plans
 - Outstanding technical issues and plans
 - **Schedule & Cost**
 - Cost to date and projection (from Sarah)
 - Resources
 - People, institutions and
 - Risk assessment; value engineering
 - Summary

Schedule/Milestones

NOW 10/2012



1.6	Software	0%	464 days
1.6.1	Online	0%	464 days
1.6.1.1	PXL	0%	251 days
1.6.1.1.1	metrology conversion into hit point software	0%	20 days
1.6.1.1.2	data format unpacker	0%	17 days
1.6.1.1.3	Slow controls integration	0%	40 days
1.6.1.1.4	error condition lookup action implementation	0%	60 days
1.6.1.1.5	plot generation and analysis of status header	0%	60 days
1.6.1.1.6	L3 - PXL online software ready for engineering run	0%	0 days
1.6.1.1.7	Online Software for production PXL	0%	45 days
1.6.1.1.8	L3 - PXL online software ready for production run	0%	0 days
1.6.1.2	IST	0%	284 days
1.6.1.2.1	Data format unpacker	0%	14 days
1.6.1.2.2	Plot generation single ladder	0%	61 days
1.6.1.2.3	Pedestal software	0%	50 days
1.6.1.2.4	Diagnostic software	0%	50 days
1.6.1.2.5	L3-online software ready for ladder tests tests	0%	0 days
1.6.1.2.6	Update software for IST layer	0%	60 days
1.6.1.2.7	L3 - IST Online Software Complete	0%	0 days
1.6.1.3	SSD	0%	195 days
1.6.1.3.1	data format unpacker	0%	25 days
1.6.1.3.2	Create Online Plots	0%	1 mon
1.6.1.3.4	Create, Program and Test Pedestal Algorithm	0%	20 days
1.6.1.3.5	SSD ready to take ladder data	0%	0 days
1.6.1.3.7	update software for complete SSD	0%	30 days
1.6.1.3.8	L3 - SSD Online Software Complete	0%	0 days
1.6.1.4	Calibration and alignment	0%	464 days
1.6.1.4.1	Survey Software	0%	180 days
1.6.1.4.1.2	CMM analysis software development	0%	9 mons
1.6.1.4.1.1	Test and verify	0%	5 mons
1.6.1.4.1.9	Internal Review of CMM survey software progress	0%	0 days
1.6.1.4.5	CMM analysis	0%	318 days
1.6.1.4.5.1	Analysis of PXL	0%	318 days
1.6.1.4.5.1.10	prototype ladder analysis	0%	3 mons
1.6.1.4.5.1.11	Database entry delivered	0%	0 days
1.6.1.4.5.1.12	production ladders	0%	4 mons
1.6.1.4.5.1.13	L3 PXL Database entry delivered	0%	0 days
1.6.1.4.5.2	Analysis of IST	0%	60 days
1.6.1.4.5.2.5	CMM analysis	0%	3 mons
1.6.1.4.5.2.6	L3 IST Database entry delivered	0%	0 days
1.6.1.4.5.3	Analysis of SSD	0%	60 days
1.6.1.4.5.3.1	CMM analysis	0%	3 mons
1.6.1.4.5.3.2	L3 SSD Database entry delivered	0%	0 days
1.6.1.6	Global Alignment	0%	240 days
1.6.1.6.1	Software Development	0%	12 mons
1.6.1.6.2	Testing phase	0%	11 mons
1.6.1.6.3	L3- Alignment prototype software review	0%	0 days
1.6.1.6.4	L3 - Alignment software for Engineering Run	0%	0 days
1.6.1.8	Self Alignment	0%	240 days
1.6.1.8.9	Software Development	0%	12 mons
1.6.1.8.10	Testing phase	0%	11 mons
1.6.1.8.11	L3- Alignment prototype software review	0%	0 days
1.6.1.8.12	L3 - Alignment software for Engineering Run	0%	0 days

CMM analysis software development

Internal Review of CMM survey software progress

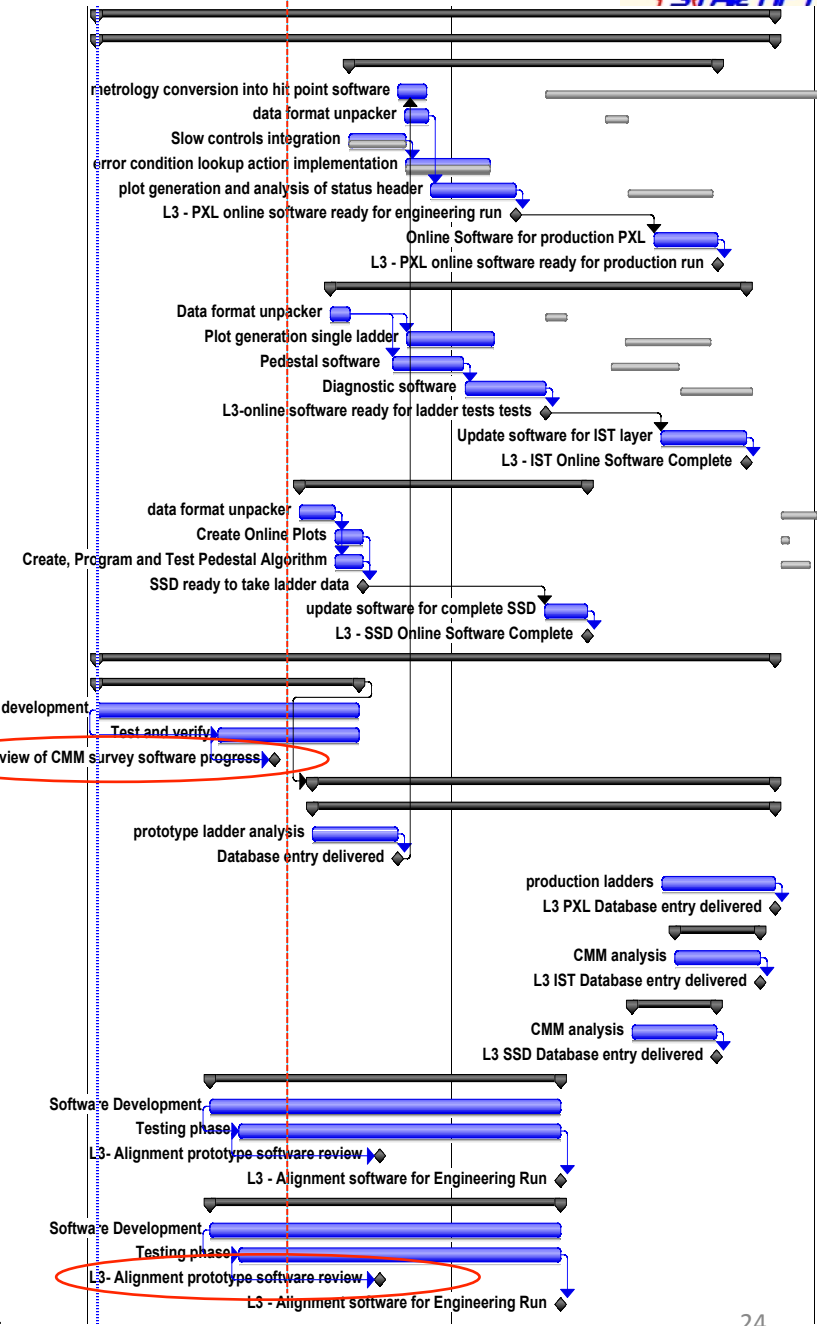

LEVEL-3 Milestones



Software			
3	Review of CMM software progress	4/5/12	5/17/12
3	Alignment software Review	9/20/12	9/20/12
3	PXL CMM database delivered for prototype	11/15/12	11/15/12
3	PXL online software ready for engineering run	12/4/12	12/4/12
3	IST online software for ladder tests	1/13/13	1/13/13
3	Alignment software ready for engineering run	1/18/13	1/18/13
3	SSD online software complete	5/14/13	5/14/13
3	IST online software complete	7/24/13	7/24/13
3	IST CMM database delivered	8/17/13	8/17/13
3	PXL CMM database delivered for production sectors	8/22/13	8/22/13
3	PXL online software ready for production run	10/1/13	10/1/13

- Survey/Alignment/Db/Online are immediate on-project activities
- Geometry/Offline/Analysis are hidden but essential tasks

-
- Brief overview of subsystem
 - Technical Progress since last review
 - Construction Plans
 - Outstanding technical issues and plans
 - Schedule & Cost
 - Cost to date and projection (from Sarah)
 - **Resources**
 - People, institutions and
 - Risk assessment; value engineering
 - Summary

Task Overview and FTE needs



FTEY

2

0.2

0.2

0.5

2

1

1.1

0.8

0.5

Total= 8.3

Software task	
Offline	
Hit Reconst.	IST
	Pixel
Tracking	
Event Vertex	
Decay Vertex	
Calibration Db	SSD
	IST
	PXL
Alignment	SSD
	IST
	PXL
Simulation	
Geometry	SSD
	IST
	PXL
Fast/Slow Sim.	SSD
	IST
	PXL
Embed./Pileup	IST
Assoc/Analysis	

- List is for *Offline* tasks only
- FTE estimates *do not* include BNL-core group contributed effort in tracking/vertexing/calibrations etc.
- Numbers are on the under-estimate side
- It comes down to about 4 FTE/year for ~two years
 - We have about half of that

Software task		BNL	IPHC	UCLA	KSU	NPI	MIT	LBL	Purdue	USTC
							X UIC			
Offline										
Hit Reconst.	IST						X			
	Pixel							X	X	
Tracking		X	X							
Event Vertex		X	X		X	X				
Decay Vertex		X	X		X	X				X
Calibration Db	SSD	X			X			X		
	IST	X					X			
	PXL	X						X	X	
Alignment	SSD	X			X			X		
	IST	X			X		X			
	PXL	X			X			X	X	
Simulation										X
Geometry	SSD	X			X			X		
	IST	X					X			
	PXL	X						X		
Fast/Slow Sim.	SSD				X			X		
	IST				X		X			
	PXL		X					X	X	
Embed./Pileup	IST				X		X	X	X	X
Assoc/Analysis		X			X	X				

IFT

NEEDS UPDATE

-
- Brief overview of subsystem
 - Technical Progress since last review
 - Construction Plans
 - Outstanding technical issues and plans
 - Schedule & Cost
 - Cost to date and projection (from Sarah)
 - Resources
 - People, institutions and
 - **Risk assessment; value engineering**
 - Summary

-
- Software Risks (rather Challenges) are related to:
 - People: (in)sufficient manpower for tasks
 - We are addressing this by prioritizing tasks and management actions
 - Overall environment functionality (tracking etc)
 - We engage in discussions with STAR S&C management for overall timeline development/understanding

Summary



- ...