

# HFT Geometry Update

S. Margetis, KSU

# HFT-PEP

Parameter	Threshold value	Optimal value
Pointing resolution of HFT system (750 MeV/c kaons)	$\leq 60 \mu\text{m}$ in the r-phi plane and Z	$\sim 45 \mu\text{m}$ in r-phi plane and Z
Single-track efficiency for HFT system, requiring PXL hits on both layers. (1 GeV/c pions)	$\geq 60\%$	$\geq 75\%$

If [beam verification] fails, the capability of the HFT system to achieve the KPPs will be demonstrated through the measurement of subsystem functional parameters and detailed, realistic simulations using the full STAR detector simulation package and analysis software.

...

The pointing resolution in r-phi and Z directions can be calculated with the full STAR detector simulation based on the design parameters, as-built dimensions, and from the results of surveys of the sensor ladders.

...

The single-track efficiency will be calculated using the full STAR simulations package with input taken from the design parameters and as-built dimensions of the detector.

HFT-PEP

# Issues

- What we have now
- The next wave as detector designs freeze
  - Anticipated timeline
- Framework (Jason)
- Importance (example)
- Resource overview and needs

Software task		BNL	IPHC	UCLA	KSU	NPI	MIT	LBL	Purdue	USTC
<b>Offline</b>										
Hit Reconst.	IST						X			
	Pixel							X	X	
Tracking		X	X							
Event Vertex		X	X		X	X				
Decay Vertex		X	X		X	X				X
Calibration Db	SSD	X			X			X		
	IST	X					X			
	PXL	X						X	X	
Alignment	SSD	X			X			X		
	IST	X			X		X			
	PXL	X			X			X	X	
<b>Simulation</b>										X
Geometry	SSD	X			X			X		
	IST	X					X			
	PXL	X						X		
Fast/Slow Sim.	SSD				X			X		
	IST				X		X			
	PXL		X					X	X	
Embed./Pileup	IST				X		X	X	X	X
Assoc/Analysis		X			X	X				

<b>ID</b>	<b>Task-name</b>	<b>Duration</b>	<b>Begin-Date</b>	<b>Predecessors</b>	<b>Resources %-Person/<b>FTE</b></b>
1.6.5.2.2	IST Global Align.	3(1) months	09/01/2011		100/ <b>0.3(0.1)</b>
1.6.5.2.3	SSD Global Align.	3(1) months	09/01/2011		100/ <b>0.3(0.1)</b>
1.6.5.3	SELF Alignment	9(4) months	09/01/2011	1.6.2.1/1.6.2.2	<b>100/0.8(0.2)</b>
1.6.5.3	Test/Verify	3(2) months	09/01/2011	1.6.2.1/1.6.2.2	<b>100/0.3(0.1)</b>
<b>1.6.6</b>	<b>Database/HFT Geometry<sup>4</sup></b>	<b>36 months</b>	<b>09/01/2010</b>		<b>300/1.1(0.4)</b>
1.6.6.1	PIXEL Geometry	6(3) months	09/01/2011		100/0.3(0.1)
1.6.6.2	IST Geometry	6(3) months	09/01/2011		100/0.5(0.2)
1.6.6.3	SSD Geometry	3(2) months	09/01/2011		100/0.3(0.1)
1.6.7	<b>Response Simulators<sup>5</sup></b>	<b>36 months</b>	<b>09/01/2010</b>		<b>200/0.8(0.3)</b>
1.6.7.2	IST Simulators	6(3) months	09/01/2011		100/0.5(0.2)
1.6.7.3	SSD Simulators	3(2) months	09/01/2011		100/0.3(0.1)
1.6.8	<b>Embedding/Assoc.</b>	<b>36 months</b>	<b>09/01/2011</b>	<b>1.6.6/1.6.7</b>	<b>100/0.5(0.2)</b>

<sup>4</sup> The estimated effort doesn't include possible/major infrastructure changes.

<sup>5</sup> The effort for PIXEL response simulator is included in the Hit Finder task. We did not account efforts for possible very-slow simulator development.

# HFT Elements



SSD+ R=22cm

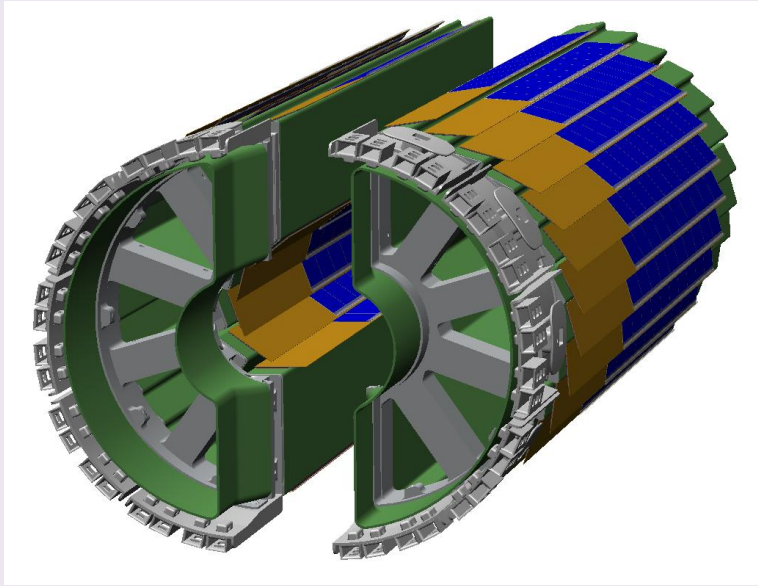

Pixel 1-2 R=2.5, 8cm

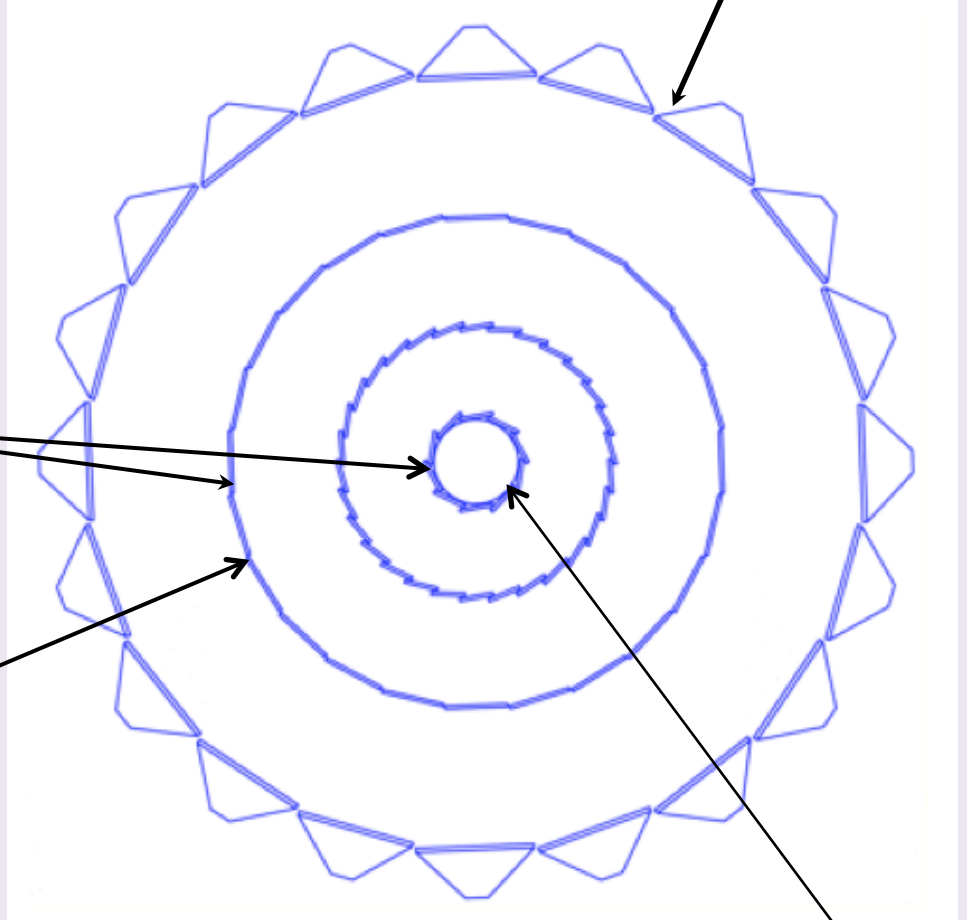

New beam pipe

IST R=14cm

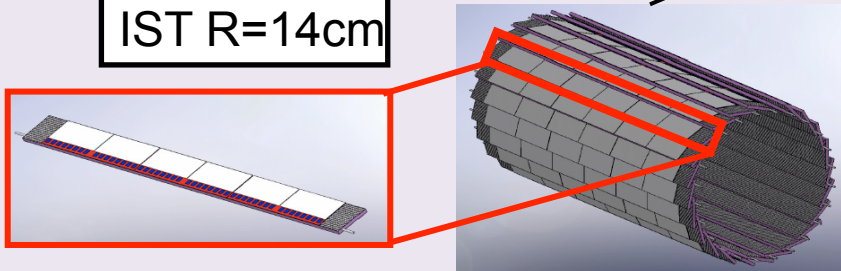

- We need design drawings
  - Need  $\langle X_0 \rangle$  estimates in sandwiched areas (glue etc)
  - Decide on appropriate abstraction level (see SVT example later)
- If 2-3 people devote 20-30% of their time to this I anticipate substantial progress in the next half year

Customer Approval:

(signature) (date)

# New Beam Pipe

REV. NO.		REVISIONS	DATE	APPROVED
1	A	Initial release.	3/22/10	D. Harris

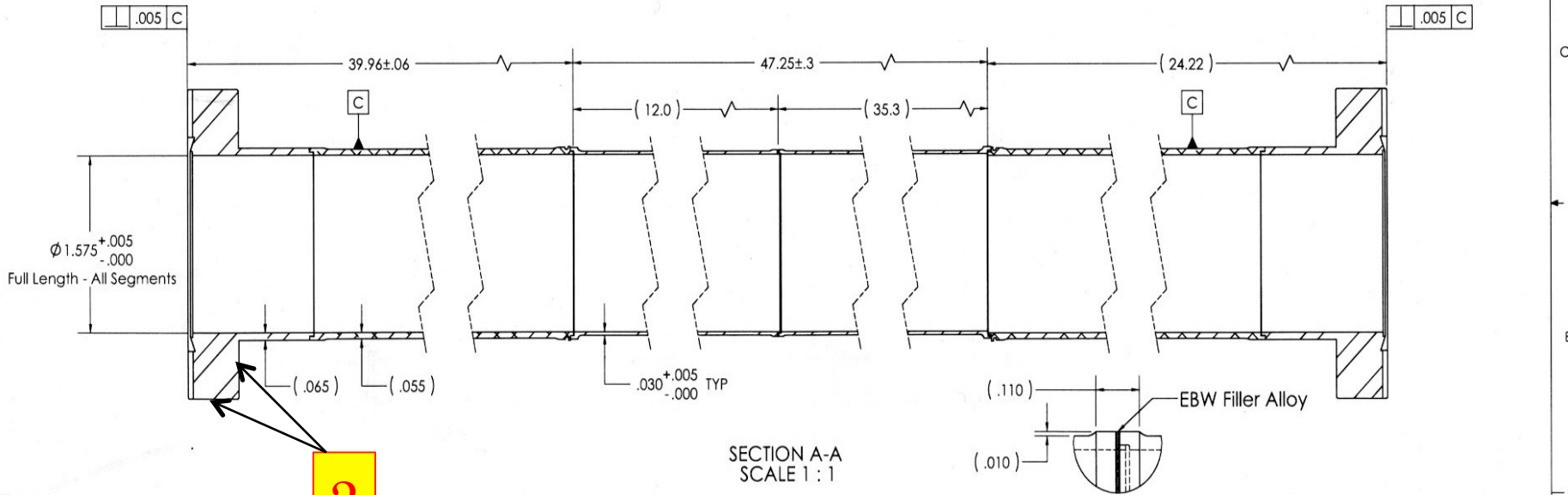
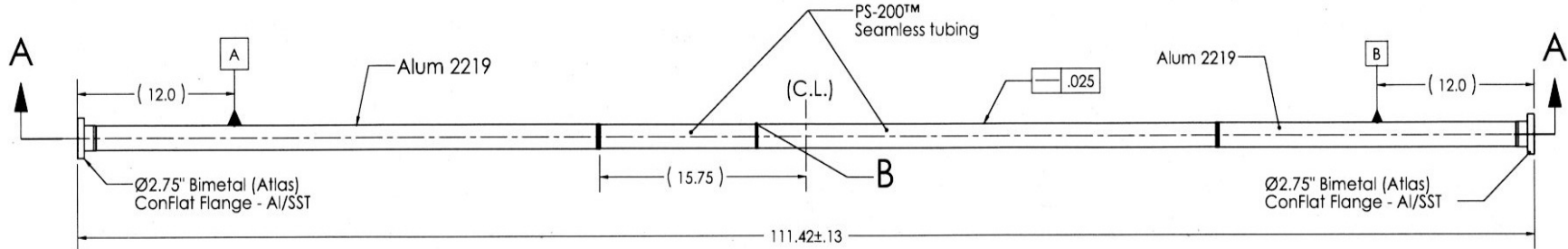

**NOTES:**

1. MATERIAL: BERYLLIUM PS-200™, 2219 ALUMINUM, Al/SST NON-ROTATABLE CONFLAT FLANGES AS SPECIFIED.
2. ASSEMBLY TO BE BAKEABLE TO 250° C.
3. ASSEMBLY TO BE VACUUM TIGHT: MASS SPEC. LEAK RATE NOT TO EXCEED 1 E-10 Std cc/sec He.
4. BERYLLIUM SECTION OD TO BE PASSIVE COATED AND BAKEABLE TO 250°c.
5. ALUMINUM SECTIONS TO BE SINGLE PIECE OR MULTIPLE SEGMENTS, AS REQUIRED TO MAINTAIN STRAIGHTNESS.
6. CONCENTRICITY OF ID TO OD FOR ALUM AND BERYLLIUM TUBES TO BE ±.003".
7. FLANGE PERPENDICULARITY TO BE DETERMINED RELATIVE TO THE ALUMINUM SEGMENT IT IS JOINED WITH.
8. STRAIGHTNESS TO BE MEASURED WITH ASSEMBLY SIMPLY SUPPORTED AT DATUMS A AND B.

INTERPRET DRAWING PER ANSI Y14.5 M-1994.		<b>BW ELECTROFUSION PROPRIETARY</b> INFORMATION INCLUDED IN THIS DOCUMENT NOT TO BE DISSEMINATED WITHOUT PRIOR WRITTEN AUTHORIZATION.		<b>BRUSHWELLMAN</b> Electrofusion Products	
UNLESS OTHERWISE SPECIFIED DIMENSIONS ARE IN INCHES.		NAME	DATE	TITLE:	
TOLERANCES:		DRAWN	D. HARRIS	EB WELD BEAM PIPE	
FRACTION: ±1/16		ENG APPR.	3/19/10	STAR	
ANGLES: ±0.5		CUSTOMER	BROOKHAVEN NATL LABS	SIZE	DWG. NO.
XX ±0.03		MATERIAL	AS NOTED	<b>B</b>	30006
XXX ±0.005		REV	A	SCALE: 1:12 DO NOT SCALE DRAWING SHEET 1 OF 1	
FINISH (Ra):	√				



# Beam Pipe



# Beam Pipe Test XML Code

```
<Document file="StarVMC/Geometry/TestGeo/TestGeo3.xml">
<Module name="TestGeo3" comment="Test of parameterized place

<Author name="Amilkar Quintero" />
<Created date="29/Jun/2011" />

<!-- What is this?-->
<CDE>
AGECOM,GCUNIT,GCONST
</CDE>

<!-- Declare all volumes -->
<Content>
    PIPE,PALU,PBER
</Content>

<!-- Pipe versioning information -->
<Structure name="PIPV">
    <var type="float" name="version" />
    <var type="int" name="config" />
</Structure>

<!-- Pipe geometry information -->
<Structure name="PIPG">

    <var type="float" name="version" />
    <var type="float" name="zoffset" />
    <var type="float" name="yoffset" />
    <var type="float" name="xoffset" />

    <var type="float" name="zoffber" />

    <var type="float" name="vacdens" />
    <var type="float" name="zslice(14)" />
    <var type="float" name="rmin(14)" />
    <var type="float" name="rmax(14)" />
```

```
</Structure>

<Export language="Morfran">
    REAL INCH/2.54;
</Export>

<!-- Fill all structures _after_ declaration of structs and variables -->
<Fill name="PIPV" comment="Pipe version" >
    <var name="version" value="1.0" comment="2.0 version of the beam pipe"/>
    <var name="config" value="1" comment="Configuration is one" />
</Fill>

<Fill name="PIPG" comment="Pipe geometry">
    <var name="version" value="1.0" comment="Default position and geometry" />

    <var name="vacdens" value="1.25E-8" comment="Vacuum density... needs to be verified" />

    <var name="xoffset" value="0.0" comment="Default x position " />
    <var name="yoffset" value="100.0" comment="Default y position " />
    <var name="zoffset" value="0.0" comment="Default z position " />

    <var name="zoffber" value="-15.75*2.54" comment="Offset of beryllium" />

    <var name="zslice" comment="Z slices in the pipe :: flange length is unknown ::" value="{-55.71 *
inch, -54.71 * inch, -54.71 * inch, -43.71 * inch, -43.71 * inch, -15.75 * inch, -15.75 * inch, 31.5 *
inch, 31.5 * inch, 43.72 * inch, 43.72 * inch, 54.71 * inch, 54.71 * inch, 55.71 * inch }" />
```

- SVT - an example of abstraction
- Detail matters (see next few slides as an example)

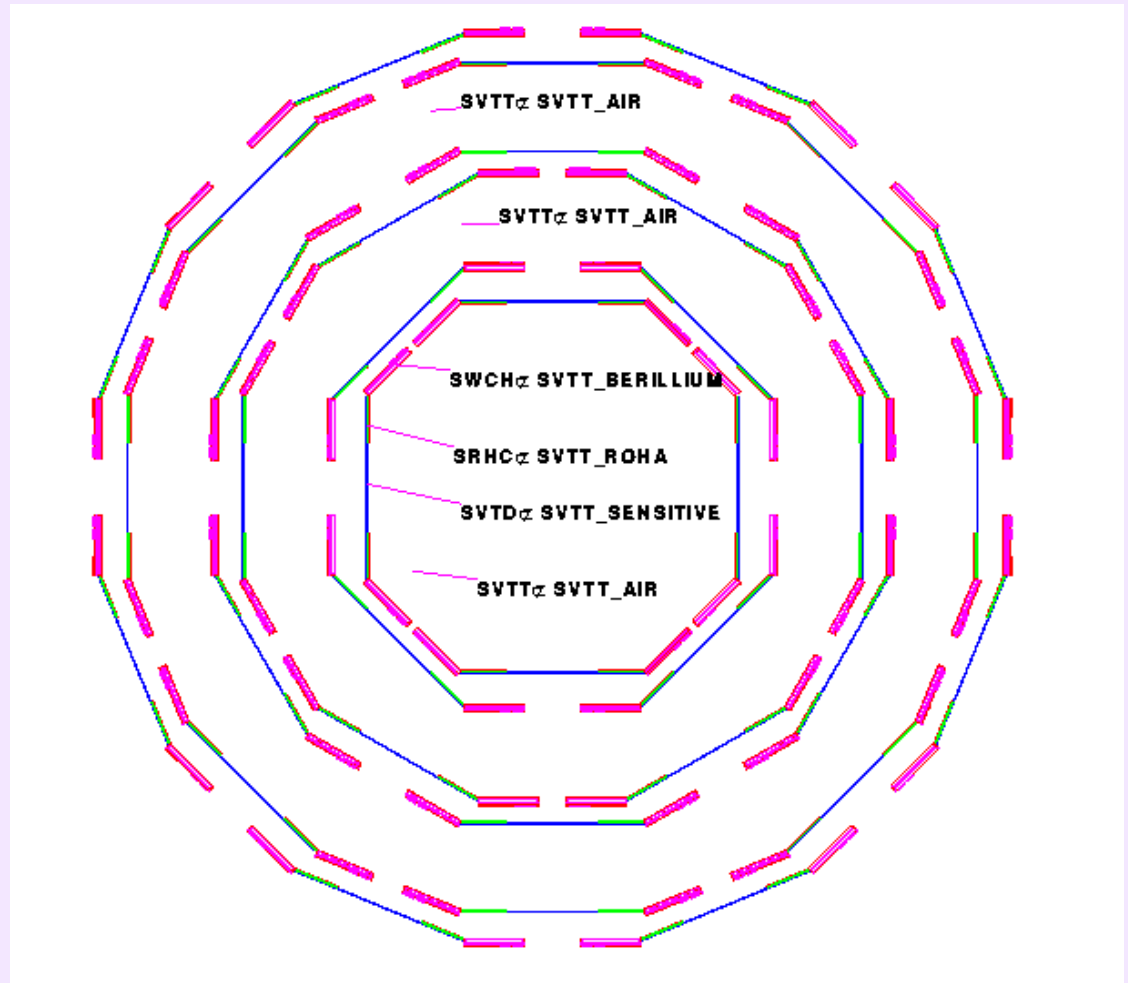

# Projection error is a strong function of first-layer distance and thickness

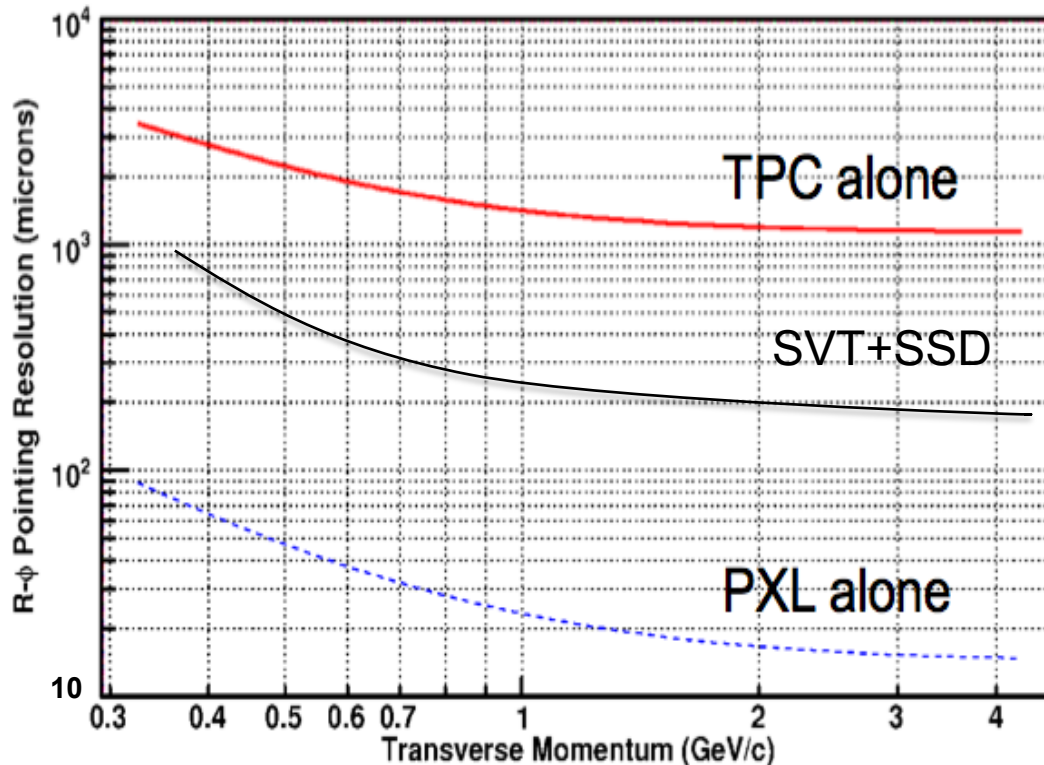
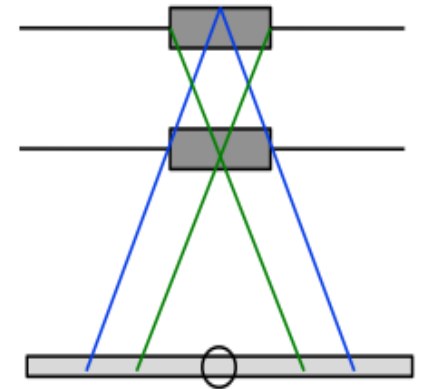

$$\sigma^2 = \frac{\sigma_1^2 r_2^2 + \sigma_2^2 r_1^2}{(r_2 - r_1)^2} + \frac{\theta_{mcs}^2 r_1^2}{\sin^2(\theta)}$$

$$\theta_{mcs} = \frac{13.6 (MeV/c)}{\beta p} \sqrt{\frac{x}{X_0}}$$

- In the critical region for Kaons from  $D^0$  decay, 750 MeV to 1 GeV, the PXL single track pointing resolution is predicted to be 20-30  $\mu\text{m}$  ... which is sufficient to pick out a  $D^0$  with  $c\tau = 125 \mu\text{m}$
- The system (and especially the PXL detector) is operating at the MCS limit

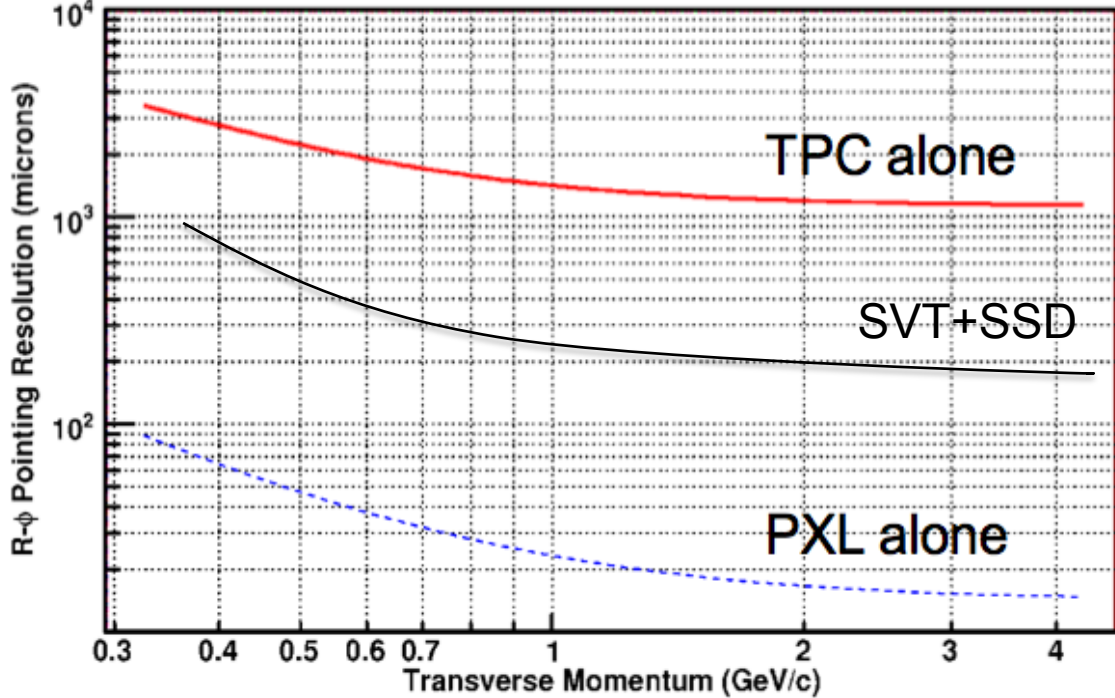

**DCA-XY**

**Simplified**

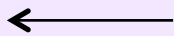

**Realistic**

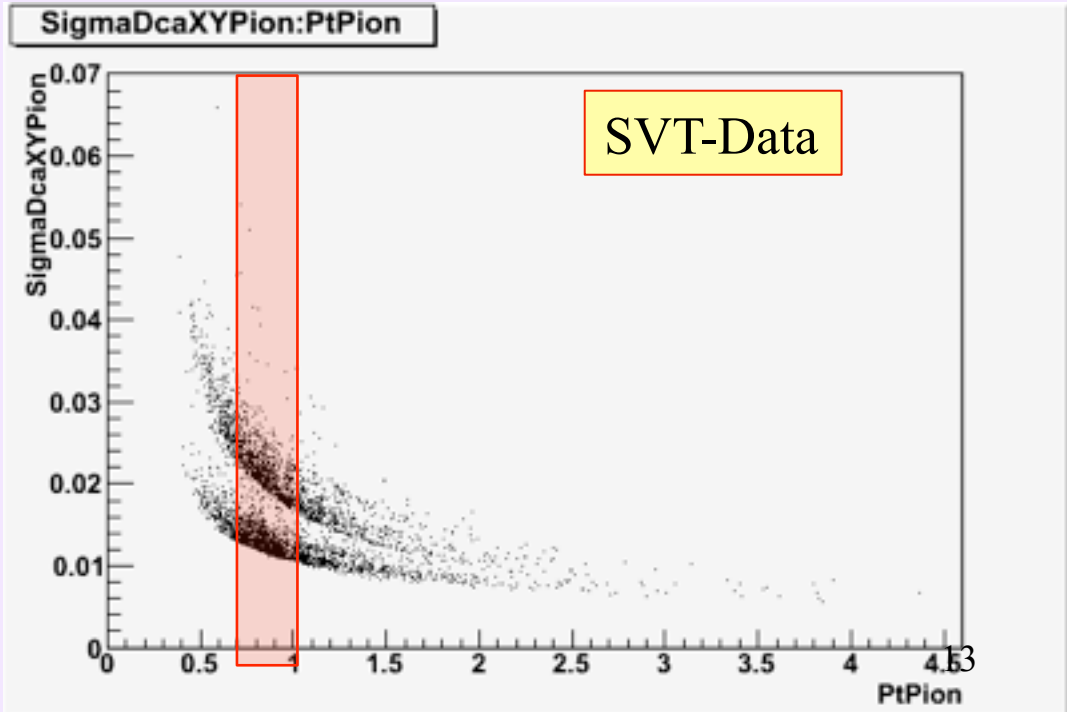

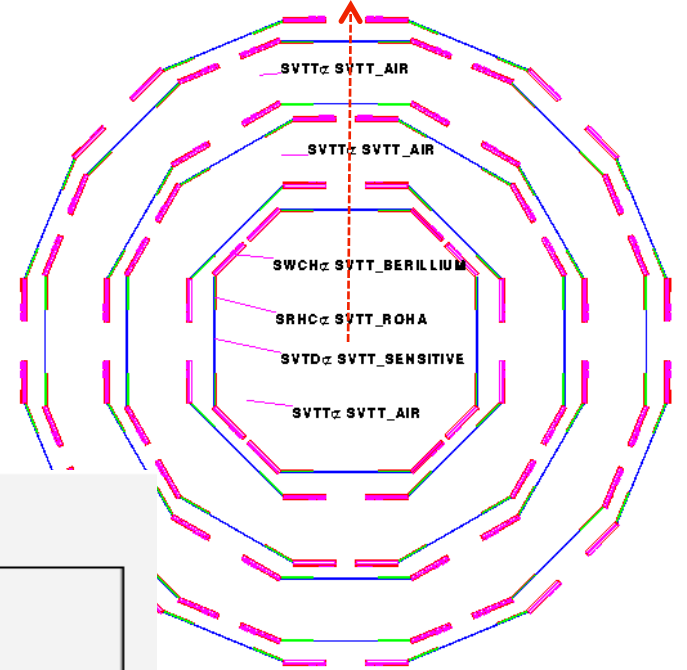

**SigmaDcaXYPion:PhiPion\*180/3.1415 {0.7<PtPion<1}**

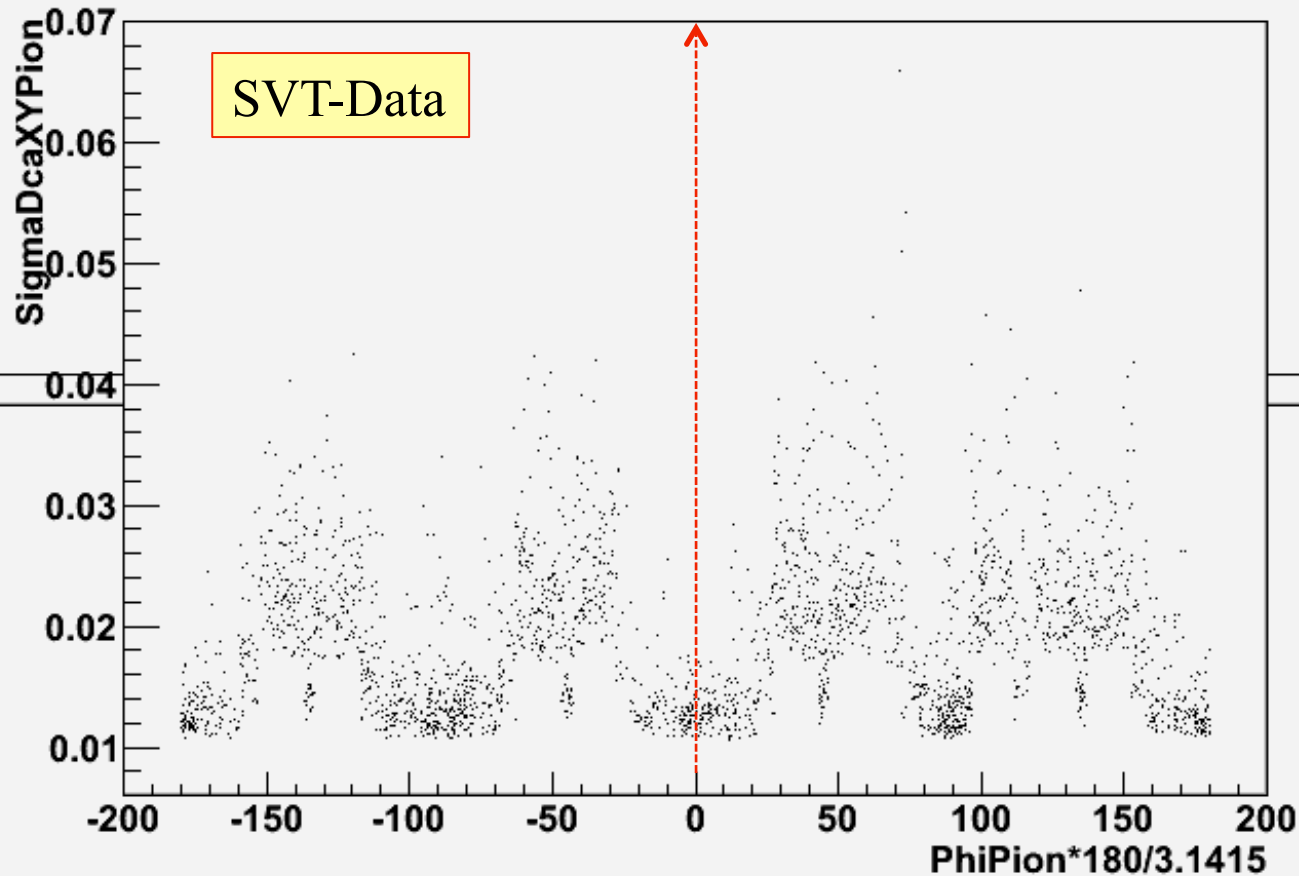

# Summary

- We are ready to move on
- We need interaction with the engineers:
  - To get the design drawings
  - For  $\langle X_0 \rangle$  estimates in sandwiched areas (glue etc)
  - Decide on appropriate abstraction level
- If 2-3 people devote 20-30% of their time to this I anticipate substantial progress in the next half year

