

## The HFT Detector-Elements Numbering Scheme

F.Videbaek, H.Wieman, H.Matis, J.Thomas, G.Nieuwenhuizen, E.Anderssen,  
S.Margetis, J.Bouchet

The HFT consists of 3 subsystems the PXL, the IST and the SST. The physical layout as well as the readout scheme for PXL is fully determined. The layout of ladders for IST and SST are well defined. The positioning of the IST and SST ladders have some freedom in terms of position in phi, while number of ladders and sensors on each is well determined.

The numbering convention in STAR is described in the controlled STAR-note **csn229B**<sup>1</sup>. In that document one also finds that the TPC is treated as a 'two-view' detector (East and West-view) due to the physical separation of East/West TPC chambers. In analogy, although the HFT subsystems are single-piece, single-'volume' detectors we adopted an appropriate 'view' for each of them. This way, the PXL detector is considered to be an East -view detector therefore we follow the STAR convention shown in fig. 4 of csn229B, whereas the former SSD was a West (default) view detector. Likewise we consider the IST a west-view detector since the symmetry matches the TPC sectors. An important consideration for a final phi-placement of the SST and IST ladders is mass distribution and 'gap' alignment between detectors, ie tracking/physics optimization. We discuss this in more detail below.

### The PIXEL detector

The fundamental structure of the PIXEL detector is the **sector** (fig. 1) like in the TPC and unlike in the SVT (where a layer was the basic one). Each sector contains 4 **ladders** each with 10 **sensors**. The following points reinforce the sector rather than layer view of PXL.

- The readout system is based on units of RDO that reads out all ladders from one sector.
- The PXL survey and internal calibration is sector based.
- Sectors are removable, such that survey and ladders geometry is sector based.
- The Geant description is also sector based with 10 identical units placed with the STAR geometry 36 degrees apart.

---

<sup>1</sup> You can find a copy here: <http://drupal.star.bnl.gov/STAR/subsys/hft>

The proposed numbering scheme for the PXL, will be a sector numbering 1 through 10 and as viewed from East (The PXL is by all means an east-side detector), as shown in fig. 1. This numbering fully complies with cs229B (fig. 4).

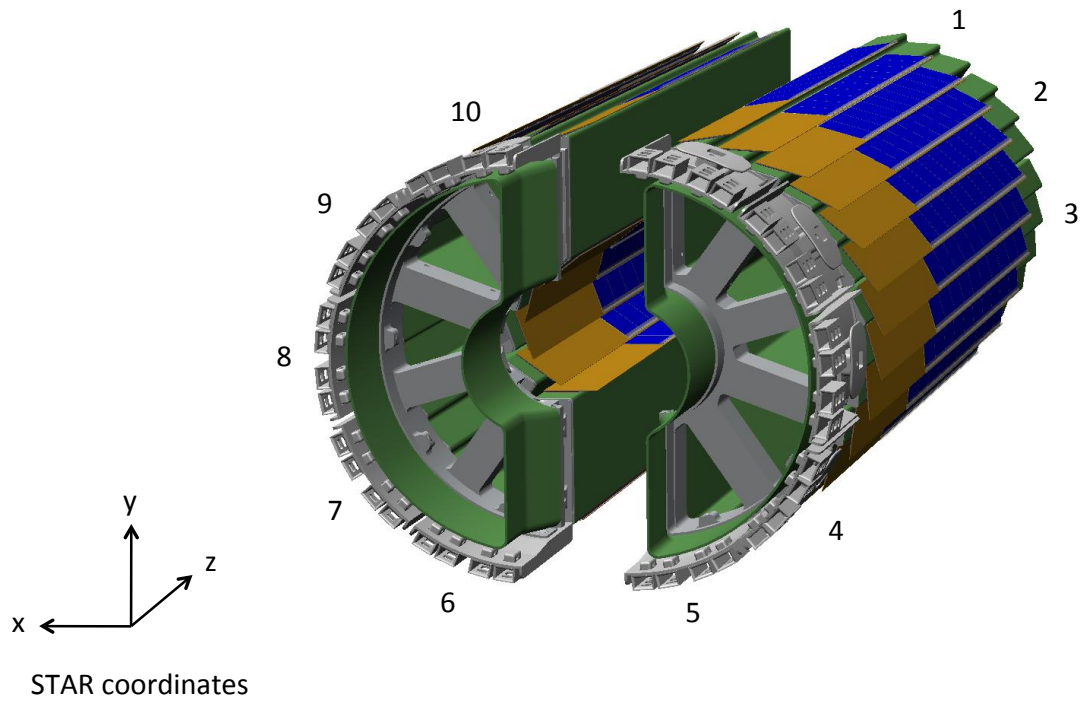

**Figure 1 The PIXEL detector layout**

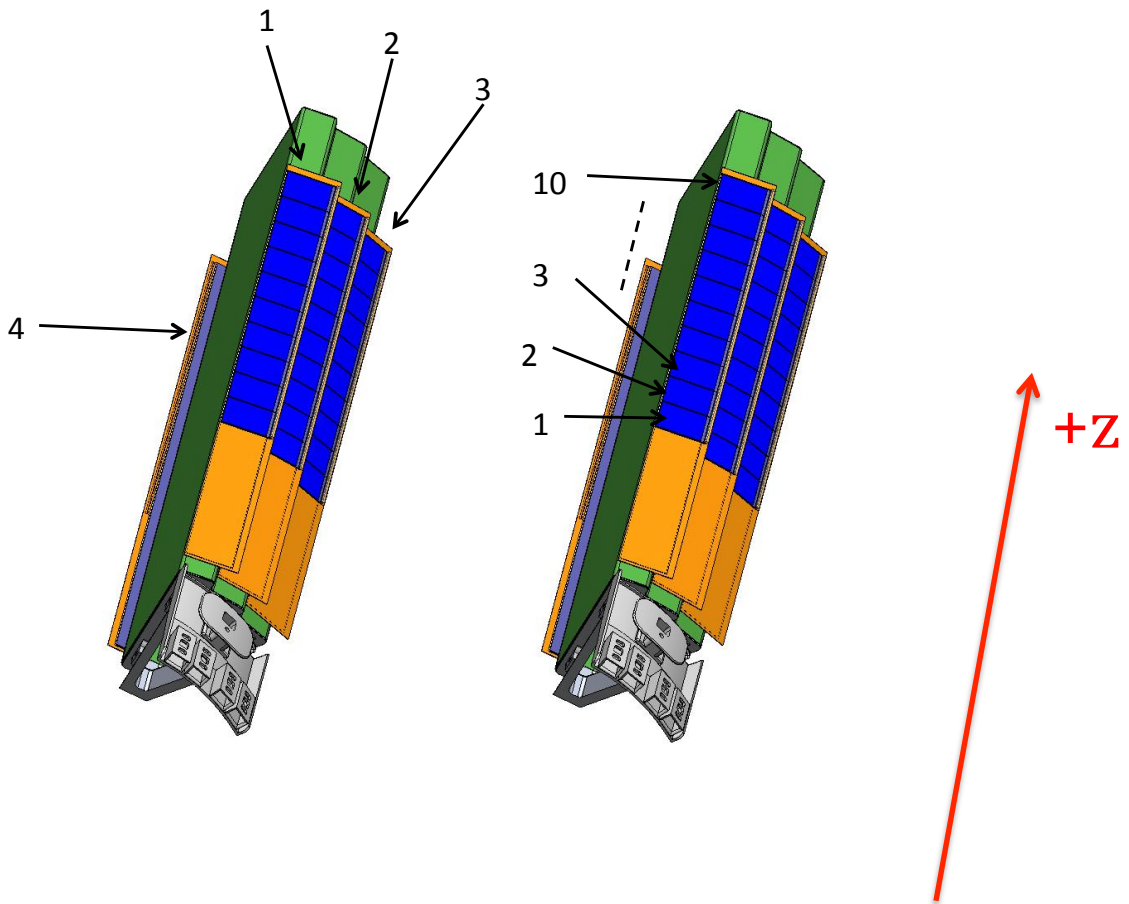

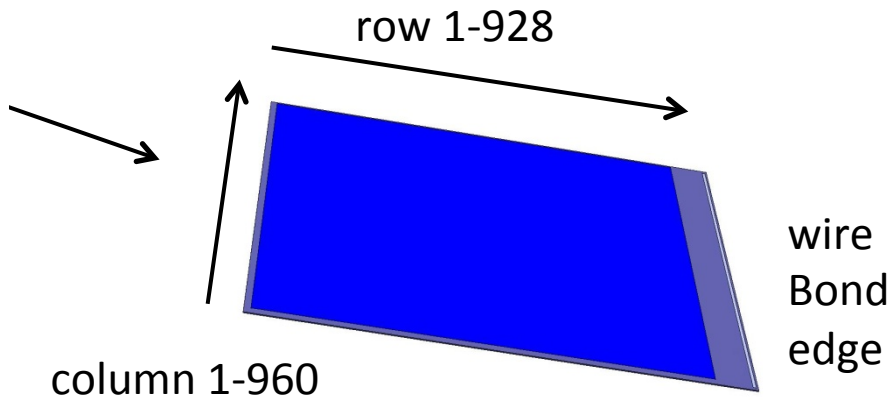

**Figure 2 The naming conventions of ladders on sectors, sensors on ladder and pixels on sensor**

Each sector has internal labeling of the ladders 1-4 (just like each TPC sector has FEE numbering and internal, fig. 11 in csn229B). In a similar manner the numbering of PXL ladders, shown in figs. 1 and 2, follows an outside-inside and clockwise sense. The 10 sensors on a ladder should be numbered from 1 through 10 counting from east (-z) to west (+z) to adhere to the STAR scheme (fig. 9 in csn229B). Figure 2 also shows the numbering convention for the individual pixels on the (ultimate) sensor.

## SST

The nomenclature for the SSD is purely for the purpose of internal software considerations. In terms of detector and physics description it will be continued to be named SSD.

The SST will consist of 20 ladders, and again these will be tiled. This symmetry matches that of the PXL, so alignment of overlap regions should probably be with that of the PXL rather than with TPC and IST where the symmetry is broken.

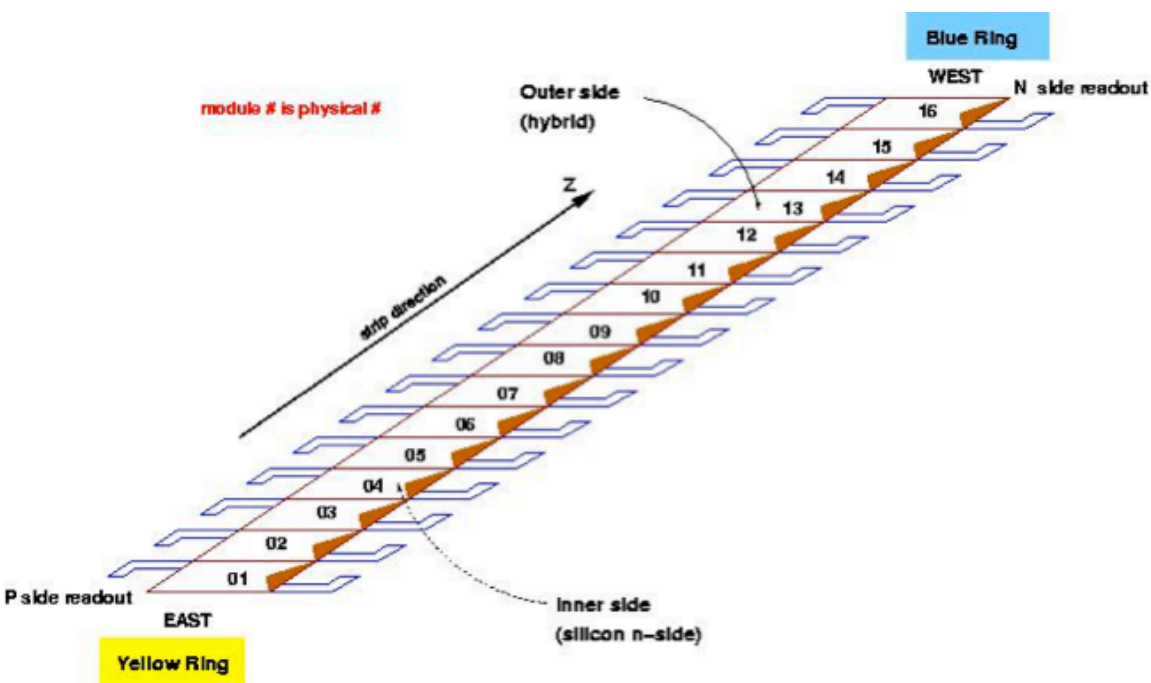
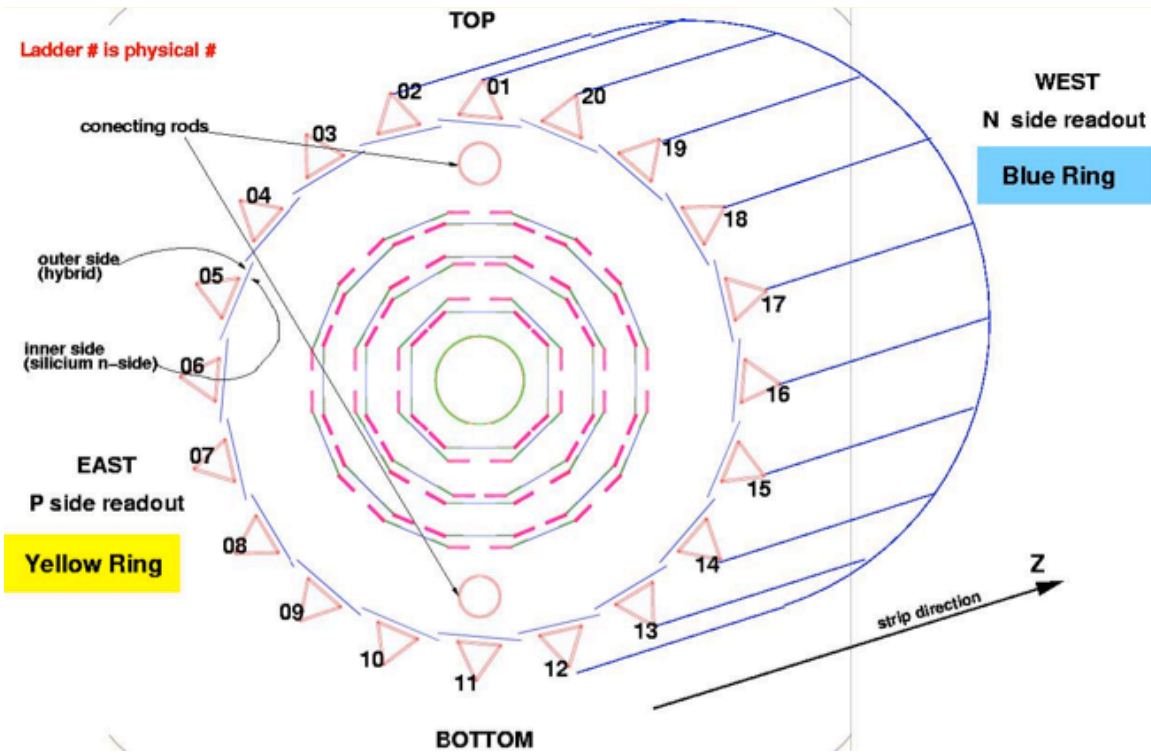

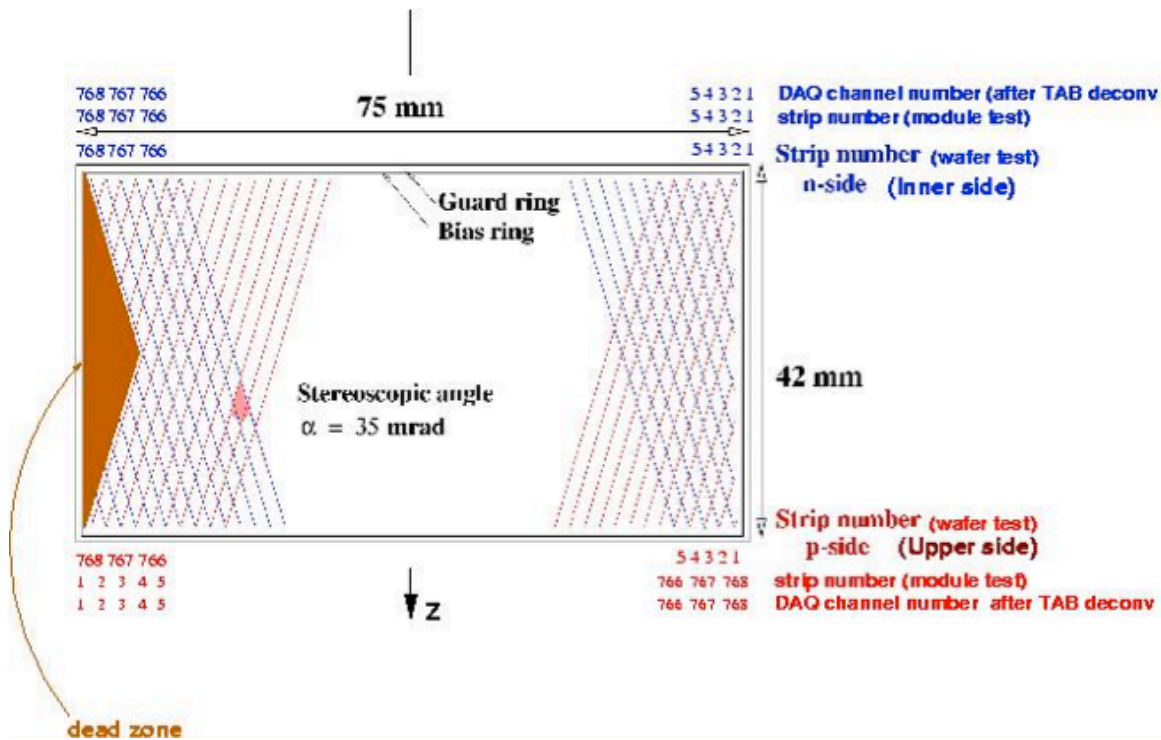

**Figure 3 The naming scheme of the former SSD. This is an East-view of the detector.**

Figure 3 shows the naming convention followed by the SST's predecessor, the SSD<sup>2</sup>. The ladder naming scheme followed there is that the SSD ladders are counted 1-20 clockwise as per STAR note starting at 12 o'clock using a West view (default) of the detector. The only non-compliant element in this numbering was that ladder-01 straddles the y-axis. In that case, a fully compliant numbering scheme should have numbered ladder-01 the ladder that is now labeled ladder-02. The numbering scheme that was used for the SSD never made it in csn229B, so we show it here (even though the SSD detector is gone) for reference purposes only.

Given the flexibility in placing the SST ladders on its support structure, one should consider and weigh arguments based on symmetry (20 SST ladders to cover 10 PXL sectors) and physics (phi profile of SST radiation thickness and its alignment to TPC and/or PXL gaps based on impact on high  $p_T$  particles). Based primarily on system symmetry arguments, pending confirmation from full-scale simulations using an adequate geometry, we proposed the aligning of the SST ladders with the PXL sectors (two ladders per sector). This layout is shown in fig. 4 that also shows the numbering of the SST ladders. This numbering incidentally fully complies with the STAR convention.

<sup>2</sup> Figure 3 plots are taken from this page:

[http://www.star.bnl.gov/public/ssd/STAR\\_technique/ssdNumerotation.html](http://www.star.bnl.gov/public/ssd/STAR_technique/ssdNumerotation.html)

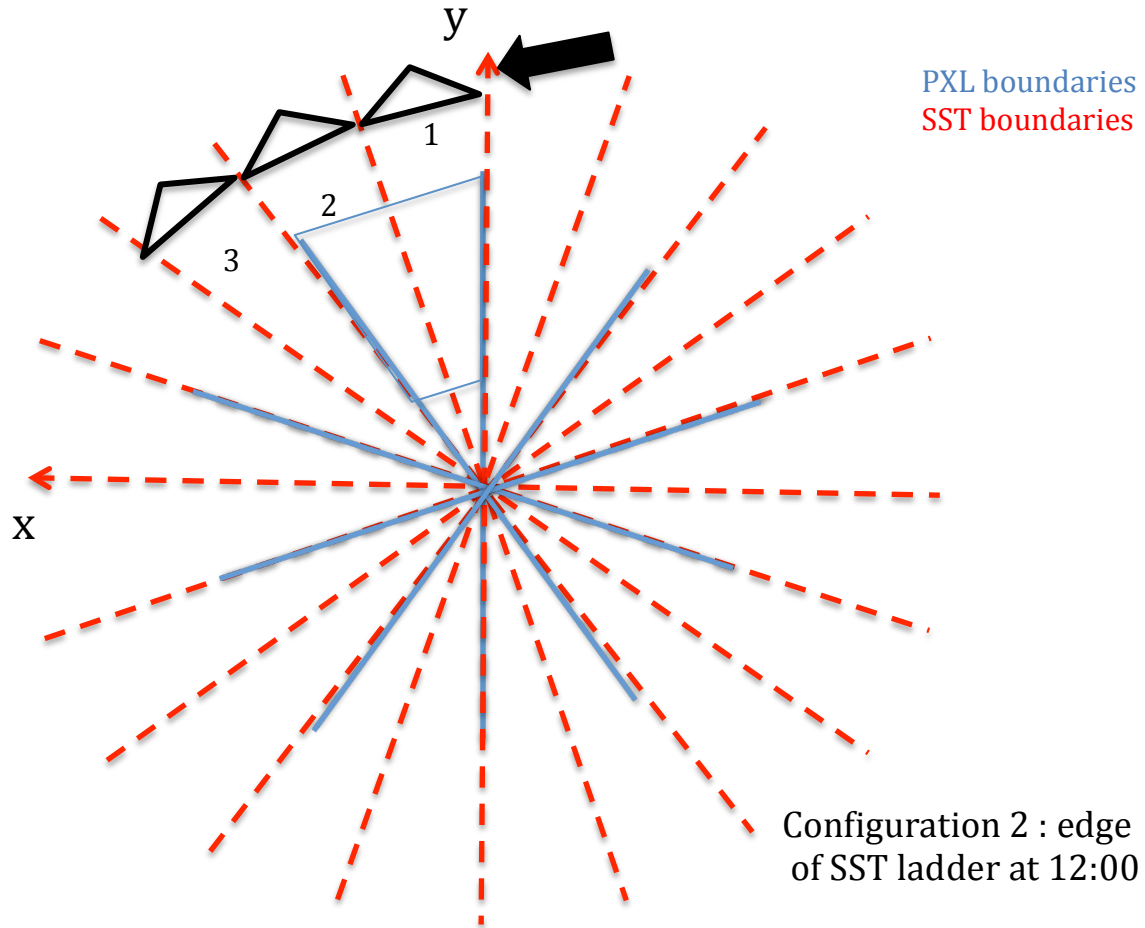
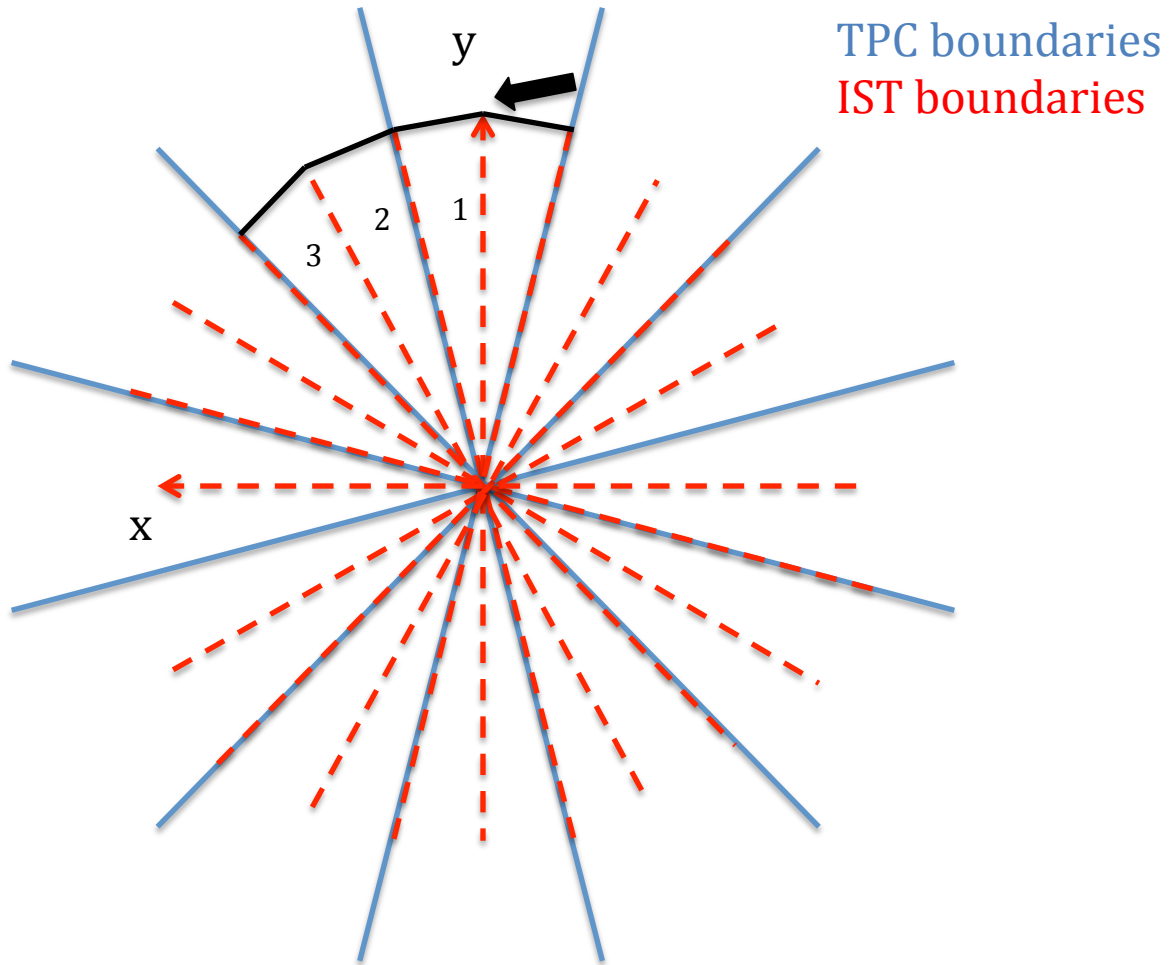

**Figure 4 The numbering of SST and its alignment with the PXL. This is an East-view of the configuration.**

## IST

The IST has a similar structure to SST (a single layer, wafer/ladder based detector) and, independent of the relative fine tuning of their ladders, the overall number scheme would be the same, e.g. a West-view ladder number etc. The IST consists of 24 ladders, exactly twice the number of TPC sectors (12). Each ladder will have 6 sensors readout by 6 APV chips each. Each sensor is a pad detector with 12 columns and 64 rows with the columns along the z-direction.

Following similar system-symmetry arguments, like in the SST case, we propose the alignment of the IST and TPC as shown in fig. 5 that also shows the proposed ladder numbering. As in the SST case this arrangement happens to also fully comply with the STAR convention.



**Figure 5 The numbering and alignment of IST with the TPC sectors. This again is an East-view of the configuration.**

(text below is to be confirmed and cross-checked with G.W et al.)

To be consistent with the STAR convention the columns should be counted 1-12 from low to high  $z$ , and the rows as 1-64 starting clockwise in  $\phi$ . I am not sure how this relates to the orientation relative to the 'read outside of the sensors i.e. where the APV chips are located, though I suspect that the chip side will be on the high  $\phi$  side.